



Compressor
Voltage Code : FZ

AJ4480P-FZ

High Temp. Commercial (HP)

220 - 240V 1~ 50 Hz

R452A / R404A / R448A / R449A / R455A / R454C AJ4480P-FZ3A

Conditions	Frequency	Nominal Cooling Capacity		Sound Power ISO3745 / ISO 3743-1
		Watts	BTU/h	
EN12900_HP / R452A	50 Hz	1883	6422	61 dBA
EN12900_HP / R404A	50 Hz	1879	6406	61 dBA
EN12900_HP / R448A	50 Hz	1885	6428	61 dBA
EN12900_HP / R449A	50 Hz	1885	6428	61 dBA
EN12900_HP / R455A	50 Hz	1812	6178	61 dBA
EN12900_HP / R454C	50 Hz	1647	5617	61 dBA

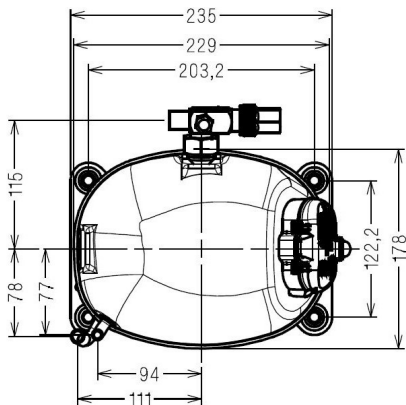
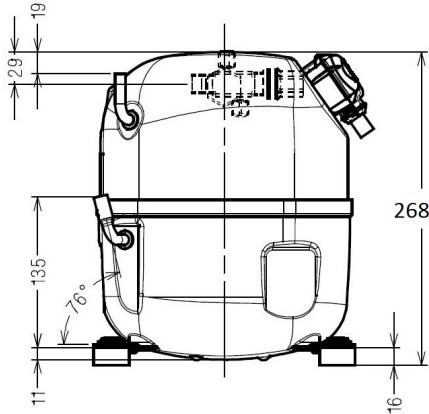

* EN12900_HP : T°Cond. 50.0°C / T°Evap. 5.0°C / T°Return gas temp.. 20.0°C
T°Subcooling. 0.0K

Certificates :

Displacement (cc)	15,2
Net Weight (Kg)	19,7
Oil Quantity (cc)	475,0
Oil Type	Polyolester
Expansion Device	Capillary_Tube/Expansion_Valve
Cooling	Fan
Main Winding (Ohm)	3,8
Start Winding (Ohm)	12,5
Current	
RLA (A)	4,4
MCC (A)	6,8
LRA (A)	24,1
Electrical Equipment	CSR
Overload	T0155
Time Check	7.5s - 14s / 15.3 A
Open Temp	105° C
Close Temp	61° C
Start Capacitor	88 µF / 250 V
Run Capacitor	15 µF / 400 V
Potential Relay	RVA4I**
Pick Up	204/233V
Drop Out	50/110V
Refrigerating connection for	
Suction Tube	12.7 (1/2")
Discharge Tube	7.9 (5/16")
Process Tube	6.35 (1/4")

Note : Tecumseh reserves the right to change information contained in this document without notification.



Tecumseh

AJ4480P-FZ	Tension FZ : 220 - 240V 1~ 50 Hz
-------------------	---

Les performances sont données dans les conditions EN12900_HP :	Gaz aspirés :	20.0 °C
Condition Dew	Sous refroidissement :	0.0 K
The performance data are in EN12900_HP conditions :	Return gas :	20.0 °C
Dew Condition	Subcooling :	0.0 K

50 Hz R452A											
											N°3634
4 T condensation	5 T évaporation	(°C)	-25	-20	-15	-10	-5	0	5	10	15
30	1 P frigorifique	(Watt)	725	941	1200	1508	1870	2294	2785	3350	3996
	2 P absorbée	(W)	458	505	549	587	621	649	670	684	690
	3 I absorbée	(A)	2.24	2.45	2.63	2.79	2.92	3.03	3.11	3.17	3.21
40	1 P frigorifique	(Watt)		765	991	1255	1562	1920	2335	2812	3359
	2 P absorbée	(W)		526	584	638	687	732	771	803	828
	3 I absorbée	(A)		2.49	2.76	3.00	3.23	3.42	3.60	3.75	3.87
50	1 P frigorifique	(Watt)			778	998	1252	1545	1883	2273	2722
	2 P absorbée	(W)			606	677	743	806	864	916	961
	3 I absorbée	(A)			2.83	3.17	3.48	3.77	4.03	4.27	4.48
60	1 P frigorifique	(Watt)				738	938	1166	1429	1733	2084
	2 P absorbée	(W)				702	788	870	947	1021	1088
	3 I absorbée	(A)				3.27	3.67	4.05	4.41	4.74	5.05

50 Hz R404A											
											N°3632
4 T condensation	5 T évaporation	(°C)	-25	-20	-15	-10	-5	0	5	10	15
30	1 P frigorifique	(Watt)	773	992	1254	1563	1925	2346	2833	3391	4025
	2 P absorbée	(W)	485	533	577	616	649	675	695	706	710
	3 I absorbée	(A)	2.37	2.58	2.76	2.92	3.05	3.15	3.23	3.28	3.30
40	1 P frigorifique	(Watt)	609	805	1032	1294	1598	1950	2355	2820	3350
	2 P absorbée	(W)	496	558	616	669	718	762	798	828	850
	3 I absorbée	(A)	2.34	2.64	2.91	3.15	3.37	3.56	3.73	3.86	3.98
50	1 P frigorifique	(Watt)		615	807	1024	1271	1554	1879	2251	2678
	2 P absorbée	(W)		569	642	712	778	839	894	943	986
	3 I absorbée	(A)		2.64	3.00	3.33	3.64	3.92	4.17	4.40	4.60
60	1 P frigorifique	(Watt)			580	752	943	1158	1404	1686	2010
	2 P absorbée	(W)			656	743	827	907	982	1051	1114
	3 I absorbée	(A)			3.04	3.46	3.86	4.22	4.57	4.88	5.17

1 = cooling capacity 2 = power input 3 = current 4 = condensing temperature 5 = evaporating temperature

Nota : Tecumseh se réserve le droit de modifier les informations contenues dans ce document sans préavis.

Note : Tecumseh reserves the right to change information contained in this document without notification.

© 2024 Tecumseh Products Company
All rights reserved



Tecumseh

AJ4480P-FZ	Tension FZ : 220 - 240V 1~ 50 Hz
-------------------	---

Les performances sont données dans les conditions EN12900_HP :	Gaz aspirés :	20.0 °C
Condition Dew	Sous refroidissement :	0.0 K
The performance data are in EN12900_HP conditions :	Return gas :	20.0 °C
Dew Condition	Subcooling :	0.0 K

50 Hz R448A (*)											
											N°3635
4 T condensation	5 T évaporation	(°C)	-25	-20	-15	-10	-5	0	5	10	15
30	1 P frigorifique	(Watt)	638	850	1104	1407	1766	2189	2683	3253	3909
	2 P absorbée	(W)	427	470	511	549	582	609	630	644	649
	3 I absorbée	(A)	2.09	2.28	2.45	2.60	2.74	2.85	2.93	2.99	3.02
40	1 P frigorifique	(Watt)		694	918	1182	1492	1856	2280	2772	3339
	2 P absorbée	(W)		494	548	599	647	690	727	757	780
	3 I absorbée	(A)		2.34	2.59	2.82	3.03	3.23	3.39	3.53	3.65
50	1 P frigorifique	(Watt)			732	958	1221	1528	1885	2300	2780
	2 P absorbée	(W)			573	640	705	766	822	873	916
	3 I absorbée	(A)			2.68	3.00	3.30	3.58	3.84	4.07	4.27
60	1 P frigorifique	(Watt)				739	956	1207	1499	1839	2235
	2 P absorbée	(W)				668	753	834	912	985	1052
	3 I absorbée	(A)				3.11	3.51	3.89	4.24	4.57	4.88

50 Hz R449A (*)											
											N°3633
4 T condensation	5 T évaporation	(°C)	-25	-20	-15	-10	-5	0	5	10	15
30	1 P frigorifique	(Watt)	638	850	1104	1407	1766	2189	2683	3253	3909
	2 P absorbée	(W)	427	470	511	549	582	609	630	644	649
	3 I absorbée	(A)	2.09	2.28	2.45	2.60	2.74	2.85	2.93	2.99	3.02
40	1 P frigorifique	(Watt)		694	918	1182	1492	1856	2280	2772	3339
	2 P absorbée	(W)		494	548	599	647	690	727	757	780
	3 I absorbée	(A)		2.34	2.59	2.82	3.03	3.23	3.39	3.53	3.65
50	1 P frigorifique	(Watt)			732	958	1221	1528	1885	2300	2780
	2 P absorbée	(W)			573	640	705	766	822	873	916
	3 I absorbée	(A)			2.68	3.00	3.30	3.58	3.84	4.07	4.27
60	1 P frigorifique	(Watt)				739	956	1207	1499	1839	2235
	2 P absorbée	(W)				668	753	834	912	985	1052
	3 I absorbée	(A)				3.11	3.51	3.89	4.24	4.57	4.88

1 = cooling capacity 2 = power input 3 = current 4 = condensing temperature 5 = evaporating temperature

(*) Veuillez vous référer strictement aux Recommandations d'Utilisation et Bulletins Marketing Tecumseh du fait de la température de reflux élevée pour les applications LBP.
 (*) Due to very high discharge temperature especially on LBP conditions, please strictly refer to Tecumseh Guidelines & Marketing Bulletin when using this refrigerant.

Nota : Tecumseh se réserve le droit de modifier les informations contenues dans ce document sans préavis.

Note : Tecumseh reserves the right to change information contained in this document without notification.

© 2024 Tecumseh Products Company
All rights reserved





Tecumseh

AJ4480P-FZ	Tension FZ : 220 - 240V 1~ 50 Hz
-------------------	---

Les performances sont données dans les **conditions EN12900_HP** :
 Condition Dew
 The performance data are in **EN12900_HP conditions** :
 Dew Condition

Gaz aspirés : 20.0 °C
 Sous refroidissement : 0.0 K
 Return gas : 20.0 °C
 Subcooling : 0.0 K

50 Hz R455A											
 N°3274											
4 T condensation	5 T évaporation	(°C)	-25	-20	-15	-10	-5	0	5	10	15
30	1 P frigorifique	(Watt)	591	794	1036	1324	1663	2062	2526	3062	3676
	2 P absorbée	(W)	396	437	475	509	539	563	581	590	591
	3 I absorbée	(A)	1.92	2.10	2.27	2.42	2.55	2.66	2.73	2.77	2.78
40	1 P frigorifique	(Watt)		643	862	1118	1419	1771	2180	2654	3198
	2 P absorbée	(W)		455	507	555	599	637	669	694	710
	3 I absorbée	(A)		2.17	2.41	2.63	2.83	3.01	3.15	3.26	3.34
50	1 P frigorifique	(Watt)			676	898	1157	1460	1812	2220	2692
	2 P absorbée	(W)			519	585	647	704	755	798	833
	3 I absorbée	(A)			2.46	2.77	3.06	3.32	3.55	3.75	3.92
60	1 P frigorifique	(Watt)				675	890	1140	1432	1773	2170
	2 P absorbée	(W)				589	674	753	827	893	951
	3 I absorbée	(A)				2.79	3.18	3.55	3.89	4.19	4.47

50 Hz R454C											
 N°3275											
4 T condensation	5 T évaporation	(°C)	-25	-20	-15	-10	-5	0	5	10	15
30	1 P frigorifique	(Watt)	537	723	944	1207	1518	1882	2306	2794	3354
	2 P absorbée	(W)	386	424	460	492	521	544	563	577	584
	3 I absorbée	(A)	1.85	2.02	2.19	2.33	2.46	2.56	2.64	2.68	2.68
40	1 P frigorifique	(Watt)		589	787	1020	1294	1613	1984	2413	2906
	2 P absorbée	(W)		439	488	532	572	607	637	660	678
	3 I absorbée	(A)		2.09	2.31	2.51	2.70	2.86	3.00	3.10	3.17
50	1 P frigorifique	(Watt)			623	824	1058	1330	1647	2015	2438
	2 P absorbée	(W)			500	562	618	669	715	753	785
	3 I absorbée	(A)			2.37	2.65	2.91	3.15	3.36	3.54	3.69
60	1 P frigorifique	(Watt)				627	820	1043	1304	1608	1961
	2 P absorbée	(W)				570	648	720	786	845	896
	3 I absorbée	(A)				2.68	3.03	3.36	3.67	3.94	4.18

1 = cooling capacity 2 = power input 3 = current 4 = condensing temperature 5 = evaporating temperature

Nota : Tecumseh se réserve le droit de modifier les informations contenues dans ce document sans préavis.
Note : Tecumseh reserves the right to change information contained in this document without notification.

© 2024 Tecumseh Products Company
All rights reserved