

Model

Designation	NF7MLX	220-240V/50Hz 1~ 208-230V/60Hz 1~	Sales code:	105F3720
-------------	---------------	--	-------------	-----------------

Compressor design

Oil type	Polyolester	Refrigerant(s)	R404A, R452A, R507
Oil viscosity	32cST	Displacement	7,27cm ³ / 0,44cu.in
Oil quantity	300cm ³ / 10,1fl.oz	Compressors on pallet	80
Refr. charge - tech. limit	400g / 14,1oz		
Free gas volume comp.	2310cm ³ / 78,1fl.oz		
Weight	10,5kg / 23,1lbs		
Motor protection	external		
Winding resistance main	4,5Ω (at 25°C)		
Winding resistance aux	12,8Ω (at 25°C)		
Max. winding temp.	125°C / 257°F		
Max. discharge temp.	130°C / 266°F		



General - Configurations with NF7MLX

	Conf. 1	Conf. 2	Conf. 3	Conf. 4
Motorconfiguration	CSIR	CSIR	CSIR	CSIR
Power supply (nominal)	220-240V/50Hz	208-230V/60Hz	220-240V/50Hz	208-230V/60Hz
Number of phases	1	1	1	1
Voltage range	187-254V	187-254V	187-254V	187-254V
Approvals	VDE, CCC, EAC, KC	VDE, CCC, EAC, KC	VDE, CCC, EAC, KC	VDE, CCC, EAC, KC
Starting torque	HST	HST	HST	HST
Note	- / -			

Applications with NF7MLX

	Conf. 1	Conf. 2	Conf. 3	Conf. 4
Refrigerant	R404A	R404A	R452A	R452A
Application	MBP	MBP	MBP	MBP
System cooling	fan 3m/s	fan 3m/s	fan 3m/s	fan 3m/s
Hot gas defrost	- / -	- / -	- / -	- / -
Long interval pull down	OK	OK	OK	OK

Electrical data - Configurations with NF7MLX

	Conf. 1	Conf. 2	Conf. 3	Conf. 4
Starting device type	relay	relay	relay	relay
Run capacitor	- / -	- / -	- / -	- / -
Start capacitor	125µF	125µF	125µF	125µF
LRA (locked rotor amps / 4s)	20A	19,4A	20A	19,4A
RLA (rated load amps / 1s)	3,7A	3,24A	3,7A	3,24A
Cut in current	20A	19,4A	20A	19,4A

Model

Designation **NF7MLX** 220-240V/50Hz 1~ 208-230V/60Hz 1~ Sales code: **105F3720**

Compressor dimensions

Housing	A Height	203mm / 7,99in
	B Height	197mm / 7,76in
	C Length shell	205mm / 8,07in
	D Length w. cover	254mm / 10in
	E Width	166mm / 6,54in

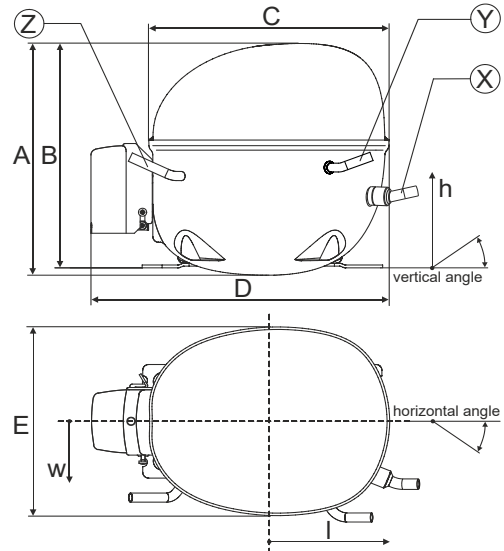

Connectors		Suction	Discharge	Process
		X	Y	Z
Diameter	[mm]	øi 9,61-9,79	øi 6,41-6,59	øi 6,41-6,59
(i:inside, o:outside)	[in]	øi 0,38-0,39	øi 0,25-0,26	øi 0,25-0,26
Material		copper	copper	copper
Horizontal angle	±2°	0°	0°	0°
Vertical angle	±2°	15°	35°	155°
Position l/h/w	[mm]	126/76/78	133/103/54	-107/94/72
	[in]	4,9/3/3,1	5,2/4/2,1	-4,2/3,7/2,8
Straight tube l.	[mm]	12	12	12
	[in]	0,5	0,5	0,5

Compressor fixation

Bolt joint

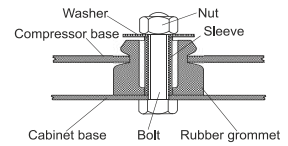
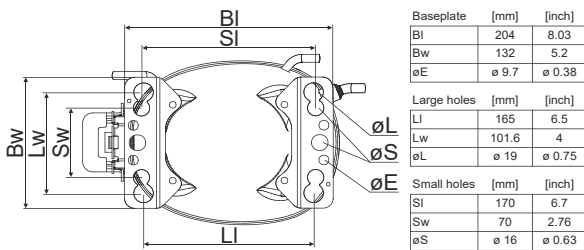

Snap-on

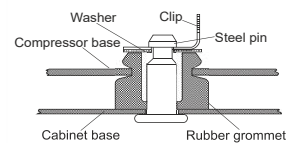

Mounting accessories	one comp.	multi pack
Bolt joint M6 ø16mm	118-1917	118-1918
Bolt joint ø1/4" ø16mm	118-1946	
Bolt joint ø1/4" ø19mm	118-1949	
Snap-on ø7,3 ø16mm	118-1947	118-1919

Application notes

LRA value on compressor label and datasheet may differ due to different test conditions for UL approval.

Model

Designation	NF7MLX	220-240V/50Hz	Conf. 1	Sales code:	105F3720
-------------	---------------	----------------------	----------------	-------------	-----------------

Configuration

Motorconfiguration	CSIR
Power supply (nominal)	220-240V/50Hz 1~
Refrigerant	R404A
Application	MBP
Voltage range	187-254V
Starting torque	HST
Approvals	VDE
	CCC
	EAC
	KC

Electrical accessories / wiring diagram

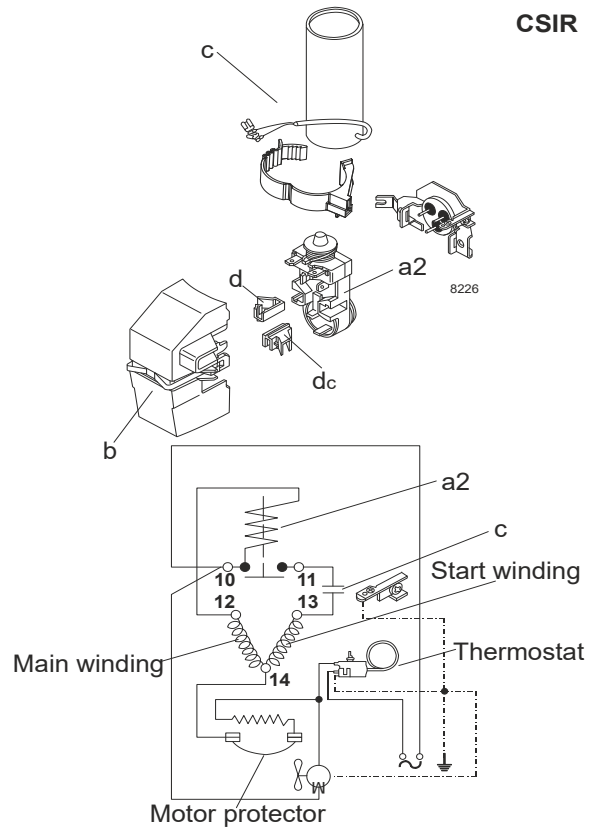

Ambient temperatures / system cooling

Ambient temperature min.:	10°C / 50°F
Ambient temperature max.:	43°C / 110°F

System cooling (n/a: outside limits)			
T ambient	LBP	MBP	HBP
32°C / 90°F	n/a	fan 3m/s	n/a
38°C / 100°F	n/a	fan 3m/s	n/a
43°C / 110°F	n/a	fan 3m/s	n/a

Operation pressure range

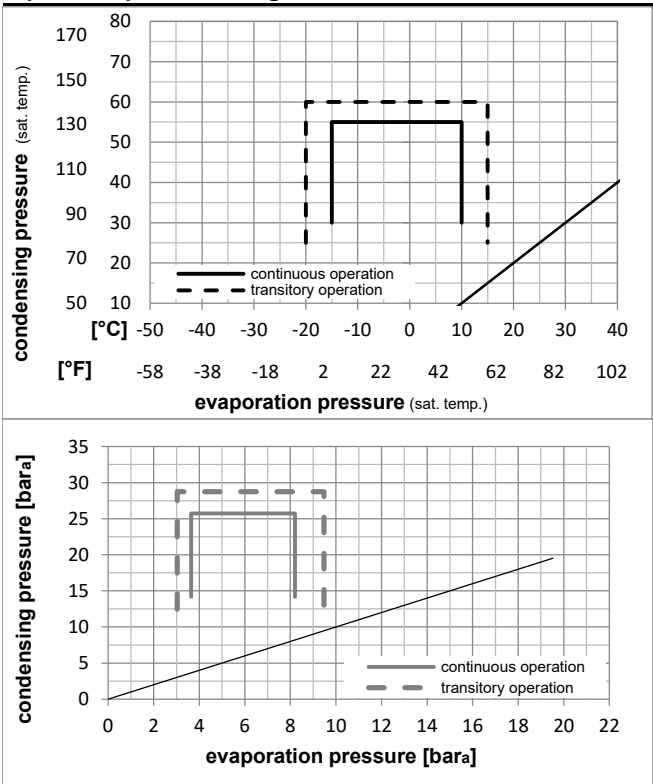

Components

a2	relay (protector: TI MRP56EN-6)	117U4139
c	start capacitor	117U5018
b	plastic cover	117U1021
d/dc	cord relief	117U0349
d/dc	cord relief	117U0349

Alternative components

a2	relay (protector: TI MRP56EN-6)	117U4139
c	start capacitor	117U5018
b	plastic cover	117U1021
d/dc	cord relief	117U0349
d	cord relief	117U0317

Model

Designation **NF7MLX 220-240V/50Hz** Conf. 1 Sales code: **105F3720**

Optimization + standard conditions

R404A, 220V/50Hz, CSIR, fan 3m/s, VDE, CCC, EAC, KC

Evaporating pressure (saturation temperature)														
Condensing pressure (saturation temperature)										Power consumption				
Return gas temp.										Current consumption				
Liquid temp.										Ref. mass flow				
Cooling capacity										COP EER				
pe	pc	RGT	Tliq	[W]	[Btu/h]	[kcal/h]	[W/W]	[Btu/Wh]	[kcal/Wh]	P1	I	m		
[°C]	[°F]	[°C]	[°F]	[W]	[Btu/h]	[kcal/h]	[W/W]	[Btu/Wh]	[kcal/Wh]	[W]	[A]	[kg/h]		
-6,66	54,4	35	46,1	682,4	2330	587,3	1,49	5,08	1,28	458,7	3,24	18,78	ASHRAE MBP	
20	130	95	115											
-10	55	32	55	506,8	1731	436,2	1,16	3,97	1,00	436,5	3,17	16,22	cecomaf MBP	
14	131	89,6	131											
-10	45	20	45	598,0	2042	514,7	1,47	5,04	1,27	405,5	3,10	18,01	EN12900 MBP	
14	113	68	113											
-6,66	48,9	18,3	48,9	622,8	2127	536,0	1,42	4,85	1,22	438,5	3,20	20,35	ARI540 MBP	
20	120	65	120											
-10	45	32	45	634,7	2168	546,2	1,57	5,35	1,35	405,5	3,10	17,48	opt	
14	113	89,6	113											
-25	45	32	45	311,7	1065	268,3	1,02	3,50	0,88	304,4	2,84	8,41	opt	
-13	113	89,6	113											

Performance tables

R404A, 220V/50Hz, CSIR, fan 3m/s, VDE, CCC, EAC, KC

	pe	Cooling capacity			COP	EER	P1	I	m		
	[°C]	[°F]	[W]	[Btu/h]	[kcal/h]	[W/W]	[Btu/Wh]	[kcal/Wh]	[W]	[A]	[kg/h]
[°C / °F]	-15	5	511,1	1746	439,9	1,37	4,67	1,18	373,7	3,01	13,96
cond. pressure	-10	14	634,7	2168	546,2	1,57	5,35	1,35	405,5	3,10	17,48
pc= 45/113	-6,7	20	726,3	2480	625,1	1,71	5,83	1,47	425,4	3,17	20,12
return gas temp.	0	32	939,8	3209	808,8	2,03	6,93	1,75	462,8	3,29	26,42
RGT= 32/90	5	41	1125,4	3844	968,6	2,31	7,88	1,98	487,9	3,39	32,06
liquid temp	7,2	45	1214,9	4149	1045,5	2,44	8,33	2,10	498,2	3,43	34,84
Tliq= 45/113	10	50	1335,9	4562	1149,7	2,62	8,94	2,25	510,6	3,49	38,66
[°C / °F]	-15	5	403,5	1378	347,3	1,01	3,46	0,87	398,6	3,06	12,80
cond. pressure	-10	14	506,8	1731	436,2	1,16	3,97	1,00	436,5	3,17	16,22
pc= 55/131	-6,7	20	583,2	1992	501,9	1,27	4,32	1,09	460,6	3,25	18,80
return gas temp	0	32	760,9	2599	654,8	1,50	5,13	1,29	506,8	3,40	24,95
RGT= 32/90	5	41	915,8	3128	788,2	1,70	5,80	1,46	538,9	3,52	30,50
liquid temp	7,2	45	990,6	3383	852,5	1,79	6,13	1,54	552,3	3,58	33,24
Tliq= 55/131	10	50	1092,0	3730	939,8	1,92	6,56	1,65	568,7	3,65	37,04

Model

Designation	NF7MLX	208-230V/60Hz	Conf. 2	Sales code:	105F3720
-------------	---------------	----------------------	----------------	-------------	-----------------

Configuration

Motorconfiguration	CSIR
Power supply (nominal)	208-230V/60Hz 1~
Refrigerant	R404A
Application	MBP
Voltage range	187-254V
Starting torque	HST
Approvals	VDE CCC EAC KC

Electrical accessories / wiring diagram

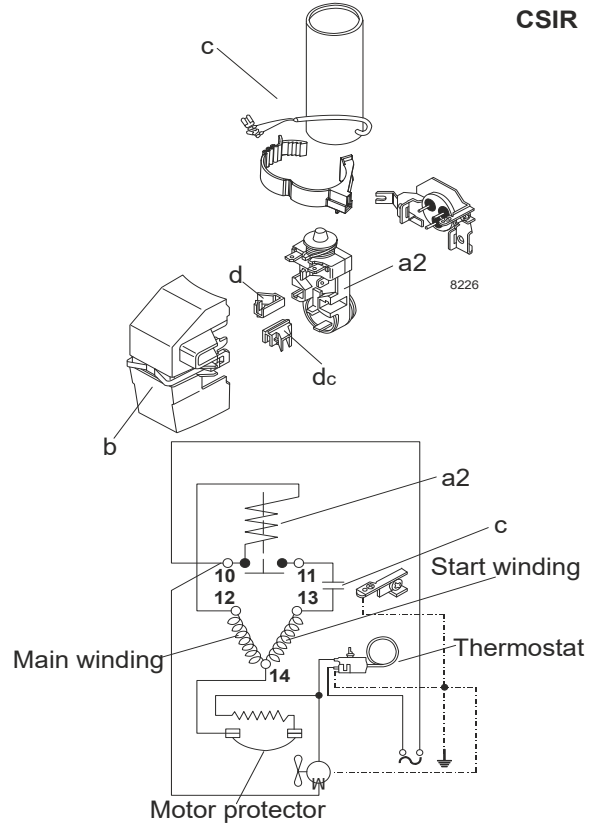

Ambient temperatures / system cooling

Ambient temperature min.:	10°C / 50°F
Ambient temperature max.:	43°C / 110°F

System cooling (n/a: outside limits)			
T ambient	LBP	MBP	HBP
32°C / 90°F	n/a	fan 3m/s	n/a
38°C / 100°F	n/a	fan 3m/s	n/a
43°C / 110°F	n/a	fan 3m/s	n/a

Operation pressure range

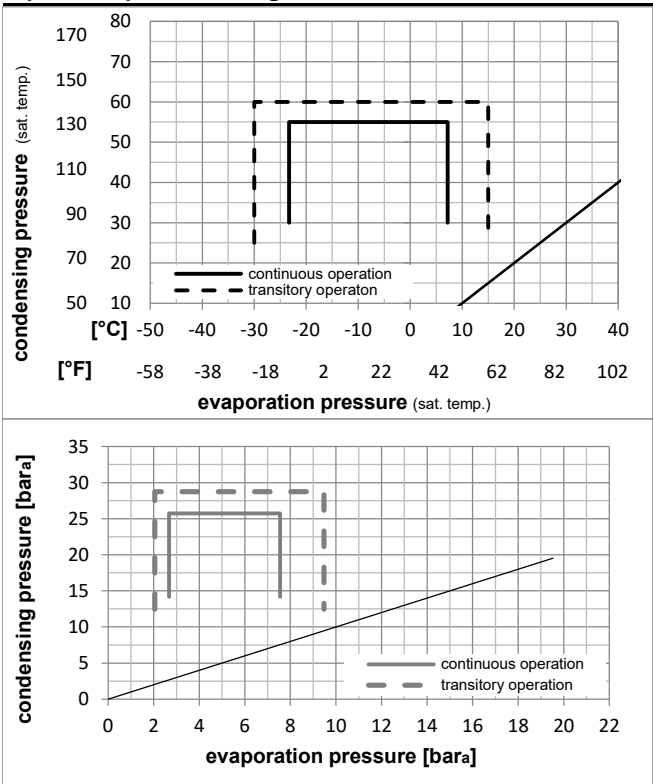

Components

a2	relay (protector: TI MRP56EN-6)	117U4139
c	start capacitor	117U5018
b	plastic cover	117U1021
d/dc	cord relief	117U0349
d/dc	cord relief	117U0349

Alternative components

a2	relay (protector: TI MRP56EN-6)	117U4139
c	start capacitor	117U5018
b	plastic cover	117U1021
d/dc	cord relief	117U0349
d	cord relief	117U0317

Model

Designation **NF7MLX 208-230V/60Hz** Conf. 2 Sales code: **105F3720**

Optimization + standard conditions

R404A, 230V/60Hz, CSIR, fan 3m/s, VDE, CCC, EAC, KC

		Evaporating pressure (saturation temperature)				Condensing pressure (saturation temperature)						Power consumption			
		Return gas temp.				Liquid temp.						Current consumption		Ref. mass flow	
		Cooling capacity						COP	EER	P1		I	m		
	pe	pc	RGT	Tliq	[W]	[Btu/h]	[kcal/h]	[W/W]	[Btu/Wh]	[kcal/Wh]	[W]	[A]	[kg/h]		
[°C]	-6,7	54,4	35	46,1	825,7	2820	710,6	1,56	5,33	1,34	529,1	3,02	22,72	ASHRAE MBP	
[°F]	20	130	95	115											
[°C]	-10	55	32	55	613,2	2094	527,8	1,24	4,23	1,06	495,6	2,90	19,63	cecomaf MBP	
[°F]	14	131	89,6	131											
[°C]	-10	45	20	45	723,6	2471	622,7	1,53	5,23	1,32	472,8	2,78	21,80	EN12900 MBP	
[°F]	14	113	68	113											
[°C]	-6,7	48,9	18,3	48,9	753,6	2574	648,6	1,46	4,99	1,26	515,5	2,95	24,63	ARI540 MBP	
[°F]	20	120	65	120											
[°C]	-10	45	32	45	768,0	2623	660,9	1,62	5,55	1,40	472,8	2,78	21,15	opt	
[°F]	14	113	89,6	113											
[°C]	-25	45	32	45	377,2	1288	324,6	1,09	3,74	0,94	344,9	2,32	10,17	opt	
[°F]	-13	113	89,6	113											

Performance tables

R404A, 230V/60Hz, CSIR, fan 3m/s, VDE, CCC, EAC, KC

	pe	Cooling capacity			COP	EER	P1	I	m		
	[°C]	[°F]	[W]	[Btu/h]	[kcal/h]	[W/W]	[Btu/Wh]	[kcal/Wh]	[W]	[A]	[kg/h]
[°C / °F]	-23	-10	413,4	1412	355,8	1,15	3,94	0,99	358,5	2,37	11,17
cond. pressure	-20	-4	489,0	1670	420,9	1,27	4,33	1,09	385,4	2,47	13,27
pc= 45/113	-15	5	618,5	2112	532,3	1,45	4,94	1,24	427,8	2,62	16,89
return gas temp.	-10	14	768,0	2623	660,9	1,62	5,55	1,40	472,8	2,78	21,15
RGT= 32/90	-5	23	940,0	3210	809,0	1,80	6,16	1,55	520,9	2,94	26,13
liquid temp	0	32	1137,1	3883	978,6	1,98	6,78	1,71	572,9	3,11	31,97
Tliq= 45/113	7,2	45	1470,0	5020	1265,1	2,24	7,65	1,93	655,8	3,35	42,15
[°C / °F]	-23	-10	314,5	1074	270,7	0,85	2,91	0,73	368,5	2,38	9,85
cond. pressure	-20	-4	379,1	1295	326,2	0,95	3,25	0,82	398,7	2,51	11,93
pc= 55/131	-15	5	488,2	1667	420,2	1,09	3,74	0,94	446,0	2,70	15,48
return gas temp	-10	14	613,2	2094	527,8	1,24	4,23	1,06	495,6	2,90	19,63
RGT= 32/90	-5	23	756,6	2584	651,1	1,38	4,71	1,19	548,2	3,10	24,49
liquid temp	0	32	920,7	3144	792,4	1,52	5,20	1,31	604,5	3,30	30,19
Tliq= 55/131	7,2	45	1198,6	4094	1031,6	1,73	5,91	1,49	693,1	3,60	40,23

Model

Designation	NF7MLX	220-240V/50Hz	Conf. 3	Sales code:	105F3720
-------------	---------------	----------------------	----------------	-------------	-----------------

Configuration

Motorconfiguration	CSIR
Power supply (nominal)	220-240V/50Hz 1~
Refrigerant	R452A
Application	MBP
Voltage range	187-254V
Starting torque	HST
Approvals	VDE CCC EAC KC

Electrical accessories / wiring diagram

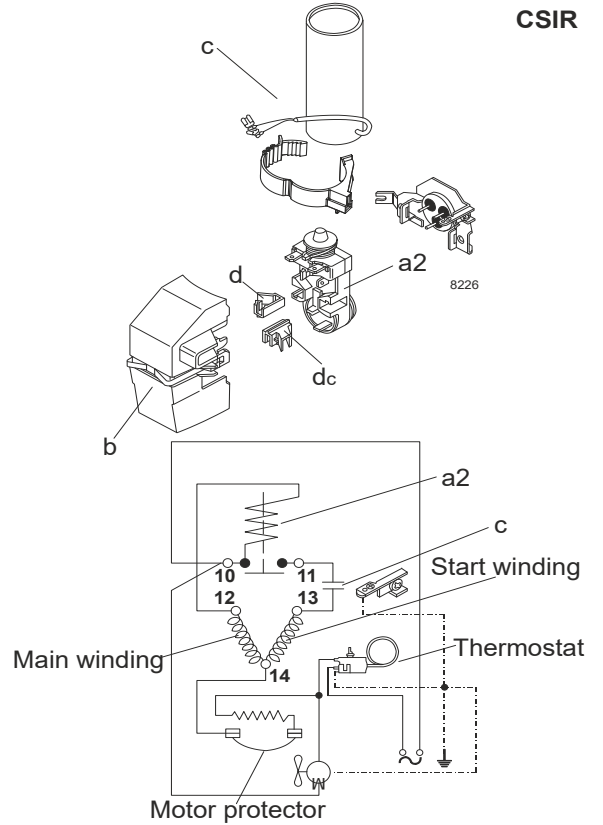

Ambient temperatures / system cooling

Ambient temperature min.:	10°C / 50°F
Ambient temperature max.:	43°C / 110°F

System cooling (n/a: outside limits)			
T ambient	LBP	MBP	HBP
32°C / 90°F	n/a	fan 3m/s	n/a
38°C / 100°F	n/a	fan 3m/s	n/a
43°C / 110°F	n/a	fan 3m/s	n/a

Operation pressure range

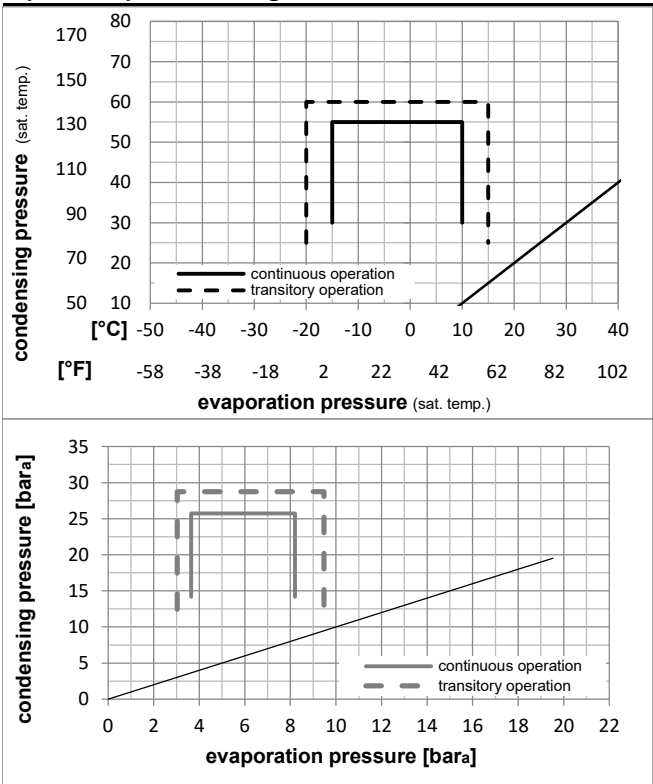

Components

a2	relay (protector: TI MRP56EN-6)	117U4139
c	start capacitor	117U5018
b	plastic cover	117U1021
d/dc	cord relief	117U0349
d/dc	cord relief	117U0349

Alternative components

a2	relay (protector: TI MRP56EN-6)	117U4139
c	start capacitor	117U5018
b	plastic cover	117U1021
d/dc	cord relief	117U0349
d	cord relief	117U0317

Model

Designation **NF7MLX 220-240V/50Hz** Conf. **3** Sales code: **105F3720**

Optimization + standard conditions

R452A, 220V/50Hz, CSIR, fan 3m/s, VDE, CCC, EAC, KC

Evaporating pressure (saturation temperature)		Condensing pressure (saturation temperature)			Return gas temp.		Liquid temp.		Cooling capacity	COP	EER	Power consumption		Ref. mass flow		
pe	pc	RGT	Tliq	[W]	[Btu/h]	[kcal/h]	[W/W]	[Btu/Wh]				[kcal/Wh]	P1			I
[°C]	[°F]	[°C]	[°F]	[W]	[Btu/h]	[kcal/h]	[W/W]	[Btu/Wh]	[kcal/Wh]	[W]	[A]	[kg/h]				
-6,66	20	54,4	130	35	46,1	115	645,8	2206	555,8	1,49	5,10	1,28	432,8	3,21	18,17	ASHRAE MBP
-10	14	55	131	32	55	131	480,5	1641	413,5	1,17	4,00	1,01	410,1	3,14	15,62	cecomaf MBP
-10	14	45	113	20	45	113	564,9	1929	486,2	1,48	5,05	1,27	381,9	3,06	17,36	EN12900 MBP
-6,66	20	48,9	120	18,3	48,9	120	592,4	2023	509,8	1,43	4,88	1,23	414,3	3,15	19,65	ARI540 MBP
-10	14	45	113	32	45	113	598,6	2044	515,2	1,57	5,35	1,35	381,9	3,06	16,87	opt
-25	-13	45	113	32	45	113	287,2	981	247,2	1,02	3,49	0,88	281,2	2,77	7,94	opt

Performance tables

R452A, 220V/50Hz, CSIR, fan 3m/s, VDE, CCC, EAC, KC

	pe	Cooling capacity			COP	EER	P1	I	m		
	[°C]	[°F]	[W]	[Btu/h]	[kcal/h]	[W/W]	[Btu/Wh]	[kcal/Wh]	[W]	[A]	[kg/h]
[°C / °F]	-15	5	478,9	1635	412,1	1,37	4,67	1,18	349,8	2,97	13,40
cond. pressure	-10	14	598,6	2044	515,2	1,57	5,35	1,35	381,9	3,06	16,87
pc= 45/113	-6,7	20	687,8	2349	591,9	1,71	5,84	1,47	402,1	3,12	19,48
return gas temp.	0	32	896,4	3062	771,5	2,03	6,94	1,75	440,9	3,23	25,73
RGT= 32/90	5	41	1078,7	3684	928,4	2,31	7,88	1,99	467,6	3,31	31,33
liquid temp	7,2	45	1166,8	3985	1004,1	2,44	8,32	2,10	478,7	3,34	34,09
Tliq= 45/113	10	50	1286,1	4392	1106,8	2,61	8,92	2,25	492,2	3,38	37,88
[°C / °F]	-15	5	379,5	1296	326,6	1,02	3,48	0,88	372,0	3,03	12,23
cond. pressure	-10	14	480,5	1641	413,5	1,17	4,00	1,01	410,1	3,14	15,62
pc= 55/131	-6,7	20	555,5	1897	478,1	1,28	4,37	1,10	434,4	3,21	18,17
return gas temp	0	32	731,1	2497	629,2	1,52	5,18	1,31	481,8	3,35	24,28
RGT= 32/90	5	41	885,0	3022	761,7	1,72	5,87	1,48	515,2	3,45	29,79
liquid temp	7,2	45	959,5	3277	825,8	1,81	6,19	1,56	529,4	3,49	32,52
Tliq= 55/131	10	50	1060,7	3623	912,9	1,94	6,62	1,67	546,9	3,54	36,29

Model

Designation	NF7MLX	208-230V/60Hz	Conf. 4	Sales code:	105F3720
-------------	---------------	----------------------	----------------	-------------	-----------------

Configuration

Motorconfiguration	CSIR
Power supply (nominal)	208-230V/60Hz 1~
Refrigerant	R452A
Application	MBP
Voltage range	187-254V
Starting torque	HST
Approvals	VDE
	CCC
	EAC
	KC

Electrical accessories / wiring diagram

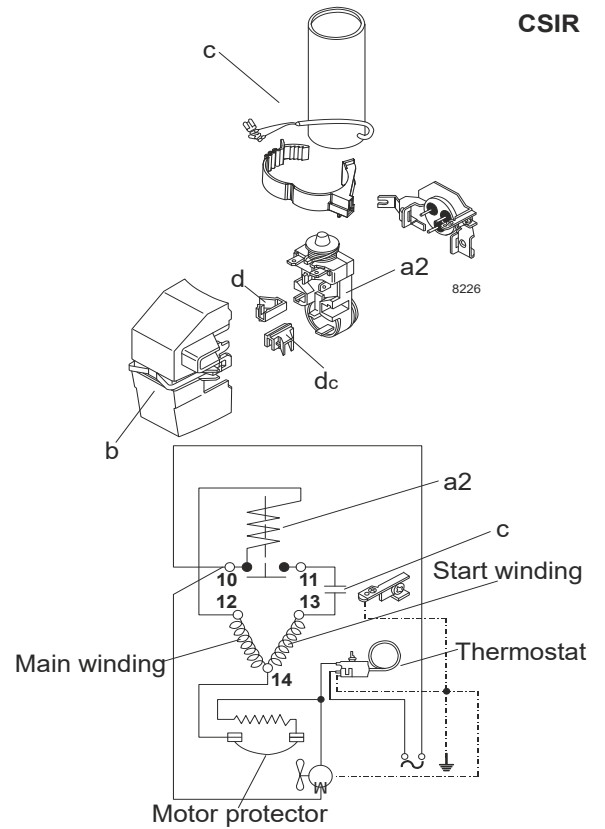

Ambient temperatures / system cooling

Ambient temperature min.:	10°C / 50°F
Ambient temperature max.:	43°C / 110°F

System cooling (n/a: outside limits)			
T ambient	LBP	MBP	HBP
32°C / 90°F	n/a	fan 3m/s	n/a
38°C / 100°F	n/a	fan 3m/s	n/a
43°C / 110°F	n/a	fan 3m/s	n/a

Operation pressure range

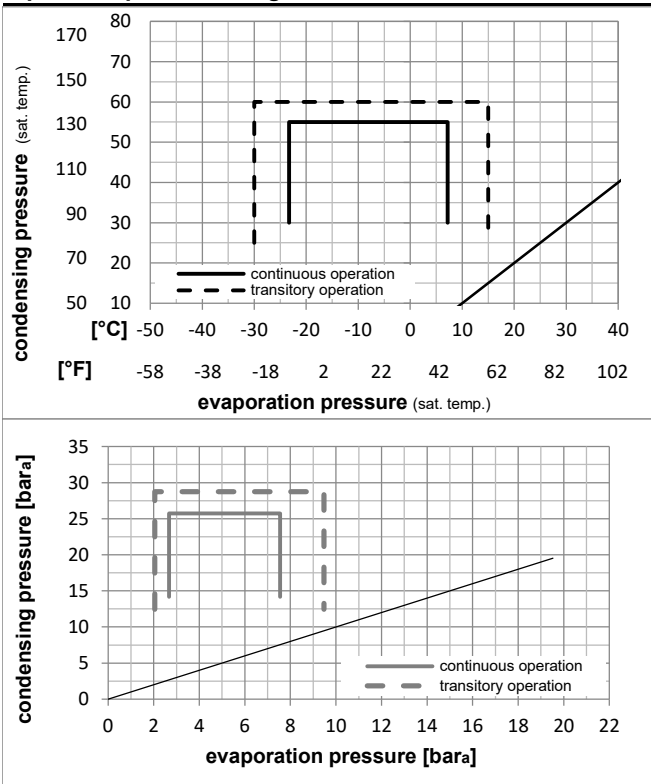

Components

a2	relay (protector: TI MRP56EN-6)	117U4139
c	start capacitor	117U5018
b	plastic cover	117U1021
d/dc	cord relief	117U0349
d/dc	cord relief	117U0349

Alternative components

a2	relay (protector: TI MRP56EN-6)	117U4139
c	start capacitor	117U5018
b	plastic cover	117U1021
d/dc	cord relief	117U0349
d	cord relief	117U0317

Model

Designation **NF7MLX 208-230V/60Hz** Conf. 4 Sales code: **105F3720**

Optimization + standard conditions

R452A, 230V/60Hz, CSIR, fan 3m/s, VDE, CCC, EAC, KC

	Evaporating pressure (saturation temperature)				Condensing pressure (saturation temperature)			Return gas temp.			Liquid temp.			Cooling capacity			COP	EER	Power consumption			ASHRAE MBP
	pe	pc	RGT	Tliq	[W]	[Btu/h]	[kcal/h]	[W/W]	[Btu/Wh]	[kcal/Wh]	P1	I	m	[W]	[A]	[kg/h]	Ref. mass flow					
[°C]	-6,66	54,4	35	46,1	780,3	2665	671,5	1,56	5,31	1,34	501,4	2,89	21,95									
[°F]	20	130	95	115																		
[°C]	-10	55	32	55	580,5	1983	499,6	1,24	4,24	1,07	467,8	2,77	18,87									
[°F]	14	131	89,6	131																		
[°C]	-10	45	20	45	682,8	2332	587,6	1,53	5,22	1,32	446,6	2,70	20,98									
[°F]	14	113	68	113																		
[°C]	-6,66	48,9	18,3	48,9	715,9	2445	616,1	1,47	5,00	1,26	488,6	2,84	23,75									
[°F]	20	120	65	120																		
[°C]	-10	45	32	45	723,5	2471	622,7	1,62	5,53	1,39	446,6	2,70	20,39									
[°F]	14	113	89,6	113																		
[°C]	-25	45	32	45	347,2	1186	298,8	1,08	3,71	0,93	320,0	2,25	9,60									
[°F]	-13	113	89,6	113																		

Performance tables

R452A, 230V/60Hz, CSIR, fan 3m/s, VDE, CCC, EAC, KC

	pe	Cooling capacity			COP	EER	P1	I	m		
	[°C]	[°F]	[W]	[Btu/h]	[kcal/h]	[W/W]	[Btu/Wh]	[kcal/Wh]	[W]	[A]	[kg/h]
[°C / °F]	-23,3	-10	381,8	1304	328,6	1,15	3,91	0,99	333,4	2,30	10,58
cond. pressure	-20	-4	454,2	1551	390,9	1,26	4,31	1,09	359,9	2,39	12,63
pc= 45/113	-15	5	578,8	1977	498,1	1,44	4,92	1,24	401,9	2,54	16,19
return gas temp.	-10	14	723,5	2471	622,7	1,62	5,53	1,39	446,6	2,70	20,39
RGT= 32/90	-5	23	891,1	3043	766,9	1,80	6,15	1,55	494,6	2,86	25,32
liquid temp	0	32	1084,0	3702	932,9	1,98	6,78	1,71	546,4	3,05	31,11
Tliq= 45/113	7,2	45	1411,7	4821	1215,0	2,24	7,66	1,93	629,0	3,34	41,24
[°C / °F]	-23,3	-10	290,9	993	250,3	0,85	2,91	0,73	341,1	2,33	9,27
cond. pressure	-20	-4	353,0	1205	303,8	0,95	3,25	0,82	371,2	2,43	11,30
pc= 55/131	-15	5	458,6	1566	394,7	1,10	3,74	0,94	418,2	2,60	14,78
return gas temp	-10	14	580,5	1983	499,6	1,24	4,24	1,07	467,8	2,77	18,87
RGT= 32/90	-5	23	721,3	2463	620,7	1,39	4,73	1,19	520,4	2,96	23,67
liquid temp	0	32	883,5	3017	760,3	1,53	5,23	1,32	576,7	3,15	29,33
Tliq= 55/131	7,2	45	1160,1	3962	998,4	1,74	5,95	1,50	665,4	3,46	39,32