

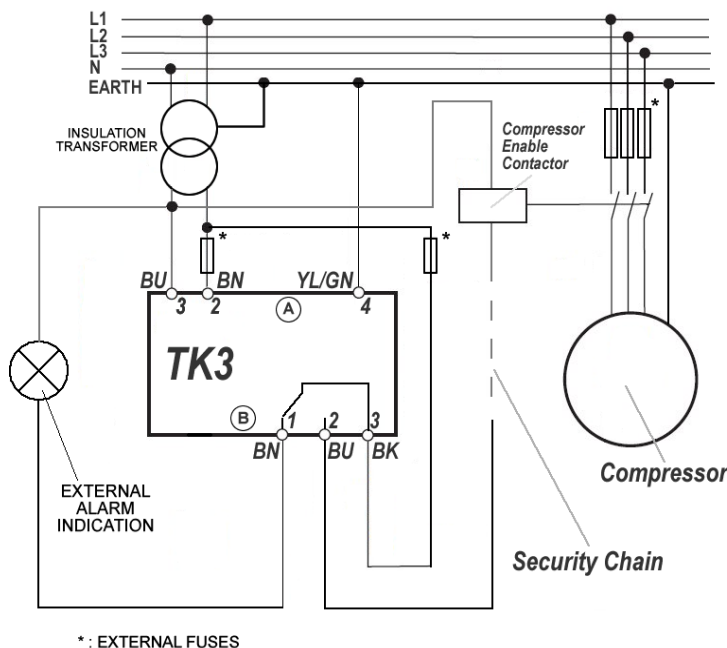

## Technical Data

<b>Supply voltage</b>	230 Vac ± 10% @50 Hz
<b>Supply Current</b>	Each TK3+ require 30VA.
<b>Electrical connection</b>	9.4mm Industry Standard Connectors / EN175301-803A connector
<b>Output signal</b>	Contact free relay output NO and NC Up to 230VAC @2A
<b>Relay output</b>	The Normally Open (NO) alarm contact (blue wire) is closed when power is applied to the TK3+
<b>Housing material</b>	Nickel plated steel
<b>Enclosure protection class</b>	IP 65
<b>Media Temperature</b>	-40°C ÷ +85°C
<b>Ambient temperature</b>	-40°C ÷ +60°C
<b>Max working pressure</b>	80 bar (higher values upon request)
<b>MOPD</b>	60 bar (higher values upon request)
<b>Oil Return Line</b>	7/16 – 20 UNEF male
<b>Cable Type</b>	PVC cable CEI 20-22. Working temp.: -20 ÷ +70 °C (fixed laying)

## Electrical Connections



Wiring Example.

To obtain a better immunity against noise eventually present on power wires it is recommended to use an insulation transformer to power the TK3+

**Electronic Sensor Connections (Industry Std. 9.4mm).**  
**Top View. The arrow indicates the glass side**

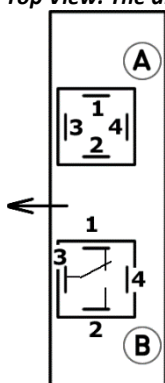

**Connector A – Power Supply**  
(cable with 3 wires and valve derivation)

2. Brown (BN): LINE
3. Blue (BU): NEUTRAL
4. Yellow/Green (YL/GN): EARTH

**Connector B – Relay**  
(cable with 3 wires)

1. Brown(BN): close in alarm
2. Blue (BU): open in alarm
3. Black (BK): common

**Valve Connection EN 175301-803 (EX DIN 43650 size A)**

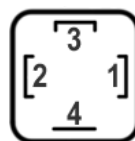

The coil is connected between pins 1 and 2 and in the supplied harness is properly wired to the A connector of the Electronic Sensor.

## Installation notes

- Only qualified personnel should carry out installation/maintenance
- Protect hands and face from contacting the oil, which may contain harmful acid.
- Depressurize the system before attempting any work
- Switch off power supply and isolate compressor
- If fitting to an existing installation, drain the compressor crankcase to just under the oil level sight glass.
- Mount the TK3<sup>+</sup> body on the compressor (see below).
- The correct oil level in the compressor crankcase must be reached before restarting the system.

## Installation instructions

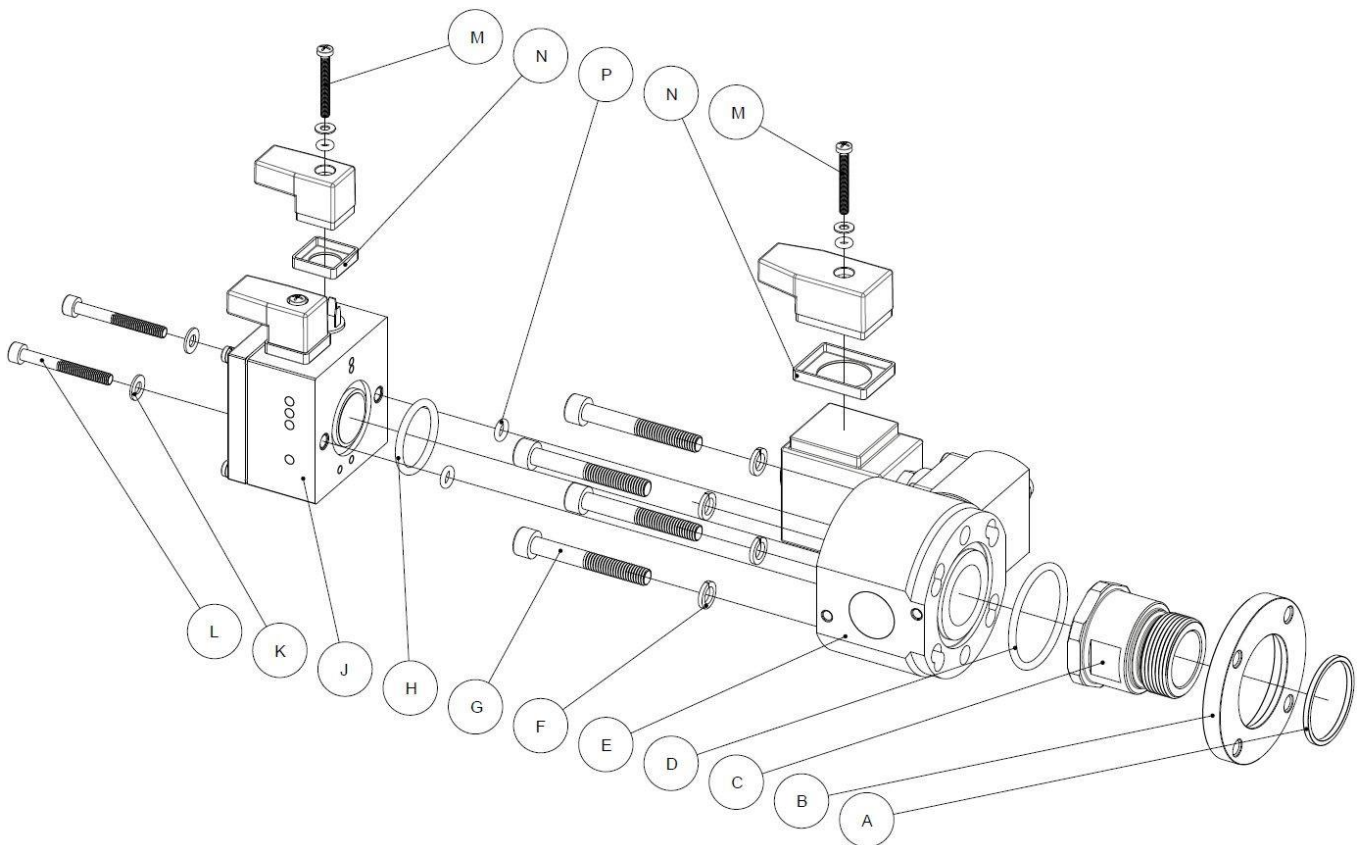

- Ensure that both the glass surfaces of the Electronic Module and of the TK3<sup>+</sup> for the electronics are dry and clean.
- Mount the TK3<sup>+</sup> body on the compressor with supplied bolts and washers using proper o-ring for the flange.
- Mount the electro-optic sensor on the TK3<sup>+</sup> body using the supplied bolts and plastic washers and o-ring for the electronics.  
NOTE. Do not apply too much strength during the screwing of the electronic module to avoid damages to the sealings of the electronic module and/or to the electrical module itself.
- Plug the Valve connector to the coil of the valve using supplied gasket and screw.
- Plug the Alarm and the Power connectors to the electro-optic sensor using supplied gaskets and screws.

NOTE. If the TK3<sup>+</sup> need an adapter to be mounted onto the compressor, first mount the adapter onto the compressor then assemble the TK3<sup>+</sup> with the adapter. In this case for the sealing between the regulator and the adapter, do not use the o-ring to be positioned on the flange's groove but only the o-ring intended for the adapter's groove.

## Mechanical Dimensions

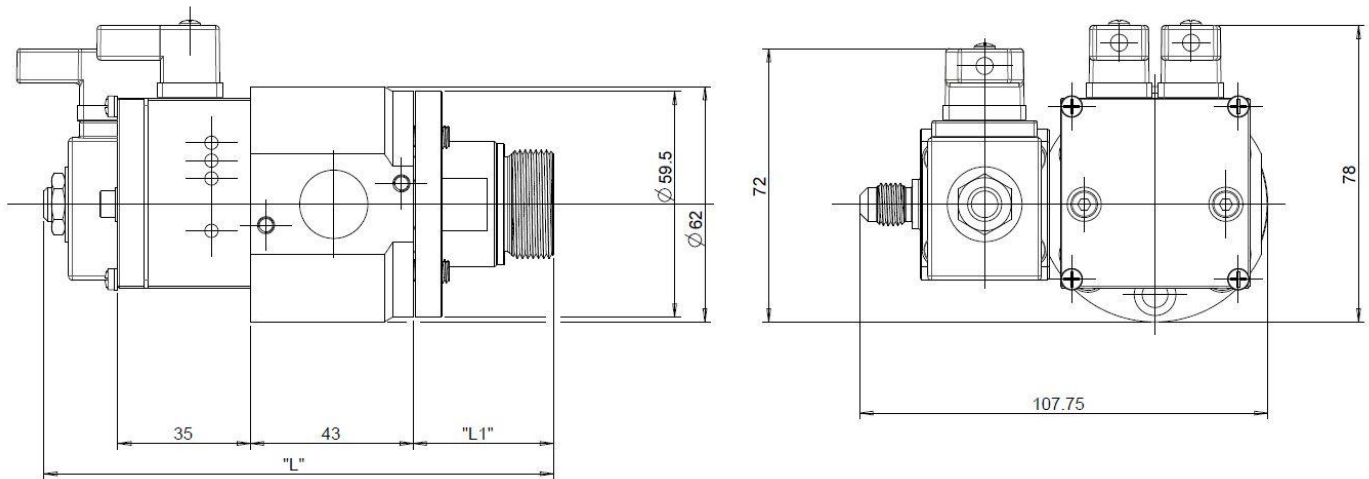

Note. - Quotes in mm - L and L1 can vary depending on the adapter (see TK3+ Adapter Addendum)

## Ordering Code Examples with mentioned timings (Other possibilities and timings available on request)

	230Vac Connectors version + 6 m cables
TK3+ Oil Level regulator	TK3P-C30BC16-02
1" 1/8 – 18 UNEF Adapter	TKX-A001
3/4" NPT Adapter	TKX-A002
3/4/6 bolts flange Adapter	TKX-A003

## Recommendations

Teklab recommends the use of a 10-micron filter in the oil line in order to protect the sensor from contamination. It is recommended to check and keep clean sensitive surfaces during major servicing. Teklab is not to be held responsible for any error on any information present in this document. The products, specifications and data reported here can be changed without the need to give any notice. The information contained in this document are based on data collected by Teklab that are considered valid and which are aligned with the technical knowledge of today. Use of this document and related products is intended only to persons having the necessary skills and knowledge at their own risk and discretion. Since conditions of use are outside the control of Teklab, we cannot assume any liability for any damage caused by the use of our equipment. This document replaces all earlier versions.