

# LKDNext

Detection and indication of refrigerant leaks

## User Guide

9MA10314.06

04/2025



---

## Legal Information

The information provided in this document contains general descriptions, technical characteristics and/or recommendations related to products/solutions.

This document is not intended as a substitute for a detailed study or operational and site-specific development or schematic plan. It is not to be used for determining suitability or reliability of the products/solutions for specific user applications. It is the duty of any such user to perform or have any professional expert of its choice (integrator, specifier or the like) perform the appropriate and comprehensive risk analysis, evaluation and testing of the products/solutions with respect to the relevant specific application or use thereof.

The Schneider Electric brand and any trademarks of Schneider Electric SE and its subsidiaries referred to in this document are the property of Schneider Electric SE or its subsidiaries. All other brands may be trademarks of their respective owner.

This document and its content are protected under applicable copyright laws and provided for informative use only. No part of this document may be reproduced or transmitted in any form or by any means (electronic, mechanical, photocopying, recording, or otherwise), for any purpose, without the prior written permission of Schneider Electric.

Schneider Electric does not grant any right or license for commercial use of the document or its content, except for a non-exclusive and personal license to consult it on an "as is" basis.

Schneider Electric reserves the right to make changes or updates with respect to or in the content of this document or the format thereof, at any time without notice.

**To the extent permitted by applicable law, no responsibility or liability is assumed by Schneider Electric and its subsidiaries for any errors or omissions in the informational content of this document, as well as any non-intended use or misuse of the content thereof.**

---

## TABLE OF CONTENTS

---

<b>CHAPTER</b>	<b>1. Introduction</b>	<b>17</b>
	1.1. General Description	17
	1.2. Environmental Characteristics	18
	1.3. Chemicals and gases interference	19
	1.3.1. Background	19
	1.3.2. Common causes of false alarms	19
	1.4. Annual Test	21
	1.5. Disposal of the device	22
	1.5.1. Disposal of electrical and electronic equipment	22
	1.5.2. Disposal of the sensors	22
<b>CHAPTER</b>	<b>2. Mechanical installation</b>	<b>23</b>
	2.1. Before Starting	23
	2.2. Disconnecting Power	23
	2.3. Operating Environment	24
	2.4. Installation Considerations	24
	2.5. Mounting of LKDNext	25
	2.6. LKDNext Dimensions	26
	2.6.1. Built-in models dimensions	26
	2.6.2. Remote version dimensions	26
	2.7. Installation	27
	2.7.1. Mounting LKDNext with DONGLE	27
	2.7.2. Mounting LKDNext with protection bracket	28
	2.7.3. Eliwell AIR App	29
	2.7.4. Correct Mounting Position	29
	2.7.5. Incorrect Mounting Position	30
	2.7.6. Minimum Clearances	30
<b>CHAPTER</b>	<b>3. Installation and Maintenance</b>	<b>31</b>
	3.1. Location instruction	31
	3.1.1. Location of sensors	31
	3.1.2. Equipment rooms	32

	3.1.3. Cold rooms .....	32
	3.1.4. Chillers .....	32
	3.1.5. Air Conditioning - Direct systems VRF/VRV .....	32
<b>CHAPTER</b>	<b>4. Connections and configurations .....</b>	<b>33</b>
	4.1. Wiring Best Practices .....	33
	4.1.1. Wiring Guidelines .....	33
	4.1.2. Rules for Removable Screw Terminals Block.....	34
	4.1.3. Special Handling Considerations .....	35
	4.1.4. Additional installation notes .....	35
	4.1.5. Electrical Connections Built-in and remote models .....	36
	4.2. Cable glands .....	38
	4.3. Built-in and remote models .....	38
	4.3.1. Cable glands Wiring Best Practice .....	39
	4.4. Refrigerant list .....	41
<b>CHAPTER</b>	<b>5. Operation .....</b>	<b>43</b>
	5.1. Device operating states.....	43
	5.2. LEDs .....	44
	5.4. Device operating states.....	45
	5.6. Service Wheel .....	47
	5.6.1. Description of the service wheel LEDs.....	49
	5.6.2. Possible configurations - Alarm/warning reset function mode (W7).....	49
	5.6.3. Service voltage value conversion table / selected function .....	50
	5.7. Setting parameters via Modbus .....	53
	5.8. Modbus network.....	54
	5.8.1. Parameters Address.....	55
	5.8.2. Resources Address .....	56
	5.9. Alarm / Warning management.....	59
	5.9.1. Alarm/warning management.....	60
<b>CHAPTER</b>	<b>6. Appendix .....</b>	<b>64</b>
	6.1. Sensor operating principle .....	64
	6.1.1. Semiconductor sensors.....	64
	6.1.2. Electrochemical sensors .....	64
	6.1.3. Pre-calibrated sensors and devices .....	64
	6.2. Sensor replacement procedure.....	65
	6.3. Cleaning the device.....	66
	6.4. Retro compatibility.....	67

---

## SAFETY INFORMATION

---

### Important information

Read these instructions carefully and visually inspect the equipment to familiarize yourself with the device before attempting to install it, put it into operation or service it. The following warning messages may appear anywhere in this documentation or on the equipment to warn of potential dangers or to call attention to information that can clarify or simplify a procedure.



The addition of this symbol to a 'Danger' or 'Warning' safety label indicates that an electrical hazard exists which will result in personal injury if the instructions are not followed.



This is the safety warning symbol. It is used to warn the user of the potential dangers of personal injury. Observe all the safety warnings that follow this symbol to avoid the risk of serious injury or death.

### DANGER

**DANGER** indicates a dangerous situation which, if not avoided, **will result** in death or serious injury.

### WARNING

**WARNING** indicates a dangerous situation which, if not avoided, **could result in** death or serious injury.

### CAUTION

**CAUTION** indicates a potentially dangerous situation which, if not avoided, **could result** in minor or moderate injury.

### **NOTICE**

**NOTICE** used in reference to procedures not associated with physical injuries.

### PLEASE NOTE

Electrical equipment should be installed, operated, serviced, and maintained only by qualified personnel. No responsibility is assumed by Eliwell for any consequences arising out of the use of this material. A qualified person is one who has skills and knowledge related to the construction and operation of electrical equipment and its installation, and has received safety training to recognize and avoid the hazards involved.

### Qualification of Personnel

Only appropriately trained persons who are familiar with and understand the contents of this manual and all other pertinent product documentation are authorized to work on and with this product. The qualified person must be able to detect possible hazards that may arise from parameterization, modifying parameter values and generally from mechanical, electrical, or electronic equipment. The qualified person must be familiar with the standards, provisions, and regulations for the prevention of industrial accidents, which they must observe when designing and implementing the system.

---

## Intended use

The products described or affected by this document, together with software, accessories, and options, are controllers, intended for commercial HVAC machines according to the instructions, directions, examples, and safety information contained in the present document and other supporting documentation.

The product may only be used in compliance with all applicable safety regulations and directives, the specified requirements, and the technical data.

Prior to using the product, you must perform a risk assessment in view of the planned application. Based on the results, the appropriate safety-related measures must be implemented.

Since the product is used as a component in an overall machine or process, you must ensure the safety of persons by means of the design of this overall system.

Operate the product only with the specified cables and accessories. Use only genuine accessories and spare parts.

Any use other than the use explicitly permitted is prohibited and can result in unanticipated hazards.

THERE IS NO GENERAL RULE for establishing the appropriate number of sensors and their location for each application. Therefore, the guidelines described below are intended as support for installers, and not as rules in their own right. ELIWELL accepts no liability for the installation of the gas detectors.

Sensors monitor a point as opposed to an area. If the gas leak does not reach the sensor then no alarm will be raised. Therefore, it is extremely important to carefully select the sensor location.

Also consider ease of access for maintenance.

The performance and overall effectiveness of the system strictly depend on the characteristics of the place where the gas detector is installed. It is therefore necessary to scrupulously comply with and carefully analyse every detail of the installation process, including (but not limited to) the following aspects:

- local, state and national regulations and standards governing the installation of gas monitoring equipment;
- electrical standards governing the laying and connection of power and signal cables to gas monitoring equipment;
- all possible environmental conditions that the devices will be exposed to;
- the physical characteristics of the gas to be detected (in particular, its specific weight);
- the characteristics of the application (for example possible leakages, movement of air, areas where gas may stagnate, high pressure areas, etc.);
- the accessibility needed for routine maintenance and repairs;
- the types of equipment and accessories needed to manage the system;
- any limiting factors or regulations that may affect system performance or installations.

**Note: This product cannot be used in place of a SAFETY device.**

**It must be used only to signal an alarm.**

- Install the sensor inside the room at a proper height depending on the refrigerant. Being gases heavier than air, it is normally recommended to position **LKDNext** sensor lower than the average height of people inside the room.
- With heavier than air gases such as halocarbon and hydrocarbon refrigerants such as R404A, propane, and butane sensors should be located near ground level. With lighter than air gas for example ammonia, the sensor needs to be located above the equipment to be monitored on a bracket or high on a wall within 300 mm of. With similar density or miscible gases, such as CO<sub>2</sub>, sensors should be mounted about head high – say 1.5 m.
- install sensor away from draughts and heat sources.

---

## Prohibited use

Any use other than that expressed above under Permitted use is strictly prohibited.

The relay contacts supplied are of an electromechanical type and subject to wear. Functional safety protection devices, specified in international or local standards, must be installed externally to this device.

Do not mount **LKDNext** sensors:

- under reflective surfaces (for example: mirrors);

## Liability and residual risks

The liability of Schneider Electric and Eliwell is limited to the proper and professional use of this product under the guidelines contained in the present and other supporting documents, and does not extend to damages caused by (but not limited to):

- Unspecified installation/use and, in particular, in contravention of the safety requirements of established legislation or specified in this document;
- Use on equipment which does not provide adequate protection against electrocution, water and dust in the actual installation conditions;
- Use on equipment in which dangerous components can be accessed without the use of specific tools;
- Installation/use on equipment which does not comply with established legislation and standards.

## Disclaimer

This document is the exclusive property of **Eliwell** and may not be reproduced or circulated without the express permission of **Eliwell**. While all possible care has been taken to ensure the accuracy of this document, **Eliwell** cannot accept liability for any damage resulting from its use. The same applies to any person or company involved in preparing and editing this document.

**Eliwell** reserves the right to make aesthetic or functional changes at any time without notice.

## SUPPORT AND CONTACT INFORMATION

T: +39 0437 166 0000

T: +39 0437 166 0060 (Italy)

T: +39 0437 166 0066 (other countries)

E: saleseliwell@se.com

Technical helpline: +39 0437 166 0005

E: techsuppeliwell@se.com

[www.eliwell.com](http://www.eliwell.com)

## Disposal



The appliance (or the product) must be disposed of separately in compliance with the local standards in force on waste disposal.

---

## ABOUT THE DOCUMENT

---

### Document Scope

This document describes the Gas detector and accessories including information on installation and wiring.

**NOTE:** Read and understand this document and all related documents, before installing, operating, or maintaining your device.

### Validity Note

The characteristics of the products described in this document are intended to match the characteristics that are available on [www.eliwell.com](http://www.eliwell.com). As part of our corporate strategy for constant improvement, we may revise the content over time to enhance clarity and accuracy. If you see a difference between the characteristics in this document and the characteristics on [www.eliwell.com](http://www.eliwell.com), consider [www.eliwell.com](http://www.eliwell.com) to contain the latest information.

### Product Related Information

#### **DANGER**

##### **HAZARD OF ELECTRIC SHOCK, EXPLOSION OR ARC FLASH**

- Disconnect all power from all equipment including connected devices, prior to removing any covers or doors, or installing or removing any accessories, hardware, cables, or wires.
- Always use a properly rated voltage sensing device to confirm the power is removed.
- Replace and secure all covers, accessories, hardware, cables, and wires and confirm that a proper ground connection exists before applying power to the unit.
- Use only the specified voltage when operating this equipment and any associated products.

**Failure to follow these instructions will result in death or serious injury.**

This device is not designed to ensure intrinsic safety when used in areas classified as hazardous.

#### **DANGER**

##### **POTENTIAL FOR EXPLOSION**

Do not use the device in hazardous locations (classified as such). <sup>(1)</sup>

**Failure to follow these instructions will result in death or serious injury.**

<sup>(1)</sup> For more information see "Directive 2014/34/EU ATEX" and "NFPA 70, Hazardous Location".



## **⚠ DANGER**

### **POTENTIAL FOR EXPLOSION**

This device is neither certified nor approved for operation in oxygen-enriched atmospheres.

**Failure to follow these instructions will result in death or serious injury.**

Semiconductor sensors detect the gas they have been calibrated for, but are also sensitive to other types of gases, solvents, alcohol, or substances containing ammonia, such as cleaning products, present in the environment. This, in certain areas and applications, can lead to false alarms when the substances described above are present. Nonetheless, although they do not only detect the specific gas, they still give a reliable indication of the concentration of the gas they have been calibrated for.

## **⚠ WARNING**

### **UNINTENDED EQUIPMENT OPERATION DUE TO ELECTROSTATIC DISCHARGE DAMAGE**

- Keep equipment in the protective conductive packaging until you are ready to install the equipment.
- Only install equipment in approved enclosures and / or locations that prevent casual access and provide electrostatic discharge protection.
- Use a conductive wrist strap or equivalent field force protective device attached to an earth ground when handling sensitive equipment.
- Always discharge yourself by touching a grounded surface or approved antistatic mat before handling the equipment.

**Failure to follow these instructions can result in death, serious injury, or equipment damage.**

## **⚠ WARNING**

### **UNINTENDED EQUIPMENT OPERATION**

- Use appropriate safety interlocks where personnel and/or equipment hazards exist.
- Install and operate this equipment in an enclosure appropriately rated for its intended environment and secured by a keyed or tooled locking mechanism.
- Power line and output circuits must be wired and fused in compliance with local and national regulatory requirements for the rated current and voltage of the particular equipment.
- Do not use this equipment in safety-critical machine functions unless the equipment is otherwise designated as functional safety equipment and conforming to applicable regulations and standards.

**Failure to follow these instructions can result in death, serious injury, or equipment damage.**

## **General Cybersecurity Information**

In recent years, the growing number of networked machines and production plants has seen a corresponding increase in the potential for cyber threats, such as unauthorized access, data breaches, and operational disruptions. You must, therefore, consider all possible cybersecurity measures to help protect assets and systems against such threats.

To help keep your Schneider Electric products secure and protected, it is in your best interest to implement the cybersecurity best practices as described in the Recommended Cybersecurity Best Practices document.

Schneider Electric provides additional information and assistance:

- Subscribe to the Schneider Electric security newsletter.
- Visit the Cybersecurity Support Portal to:
  - Find Security Notifications
  - Report vulnerabilities and incidents
- Visit the Schneider Electric Cybersecurity and Data Protection Posture to:
  - Access the cybersecurity posture
  - Learn more about cybersecurity in the cybersecurity academy
  - Explore the cybersecurity services from Schneider Electric

---

## Environmental Data

For product compliance and environmental information refer to the Schneider Electric Environmental Data Program.

## Related Documents

Title of documentation	Reference number
Cybersecurity Best Practices	Refer to "General Cybersecurity Information" page 9
LKDNext Instruction Sheet	9IS64882

To find documents online, visit the Eliwell website ([www.eliwell.com](http://www.eliwell.com)).

## Terminology Derived from Standards

The technical terms, terminology, symbols and the corresponding descriptions in this manual, or that appear in or on the products themselves, are generally derived from the terms or definitions of international standards. In the area of functional safety systems, drives and general automation, this may include, but is not limited to, terms such as *safety*, *safety function*, *safe state*, *fault*, *fault reset*, *malfunction*, *failure*, *error*, *error message*, *dangerous*, etc.

## Information on Non-Inclusive Terminology

As part of a group of responsible, inclusive companies, we are updating our communications and products that contain non-inclusive terminology. Until we complete this process, however, our content may still contain standardized industry terms that may be deemed inappropriate by our customers.

## Type Code

### Device Type Code

Type code description							
<b>LKDN67IR00BSK</b>	LKDN	67	IR	00	B	S	K
Product Family	LKDNNext series						
IP	67 = IP67						
Sensor Technology			IR	Infrared			
			SC	Semiconductor			
			EC	Electrochemical			
Refrigerant Group			00	CO2			
			01	Type 1. R32 mixtures			
			02	Type 2. HFC/HFO			
			03	Type 3. Hydrocarb. refr. (HC)			
			04	Ammonia (NH3) 100ppm			
			05	Ammonia (NH3) 1000ppm			
			06	Ammonia (NH3) 5000ppm			
Sensor Version					B	Built-in	
					R	Remote	
Device Type						S	Standard device
BlueTooth						K	With DONGLE BTLE 5.0 AIR
						blank	single device

### Spare sensors Type Code

Type code description							
<b>LKDN67IR00SS</b>	LKDN	67	IR	00	S	S	
Product Family	LKDNNext series						
IP	67 = IP67						
Sensor Technology			IR	Infrared			
			SC	Semiconductor			
			EC	Electrochemical			
Refrigerant Group			00	CO2			
			01	Type 1. R32 mixtures			
			02	Type 2. HFC/HFO			
			03	Type 3. Hydrocarb. refr. (HC)			
			04	Ammonia (NH3) 100ppm			
			05	Ammonia (NH3) 1000ppm			
			06	Ammonia (NH3) 5000ppm			
Sensor Version					S	Spare sensor	
Device Type						S	Standard device

Spare accessory Type Code

Type code description						
<b>LKDN67AAAAAB</b>	LKDN	67	AA	AA	A	B
Product Family	LKDNext series					
IP	67 = IP67					
Sensor Style	AA Accessory					
Refrigerant	AA Accessory					
Sensor Version	A Accessory					
Device Type	B Guarding bracket					

**Gas Detector LKDNext series part numbers**

LKDNext Reference	Description	Refrigerant	Sensor style	Sensor technology	Sensor type	Operating range [ppm]	Power Supply
<b>LKDN67IR00BS</b>	LKDNext, CO2, IR 10000 ppm, Built-in, AO, DO, Modbus	CO2	Built-in	IR	/	10,000	24 Vdc ±20% 24 Vac ±20% 50/60 Hz
<b>LKDN67SC01BS</b>	LKDNext, R32mix, SC 1000 ppm, Built-in, AO, DO, Modbus	R32 mixtures		Type 1 (R32 mixtures)	1,000		
<b>LKDN67SC02BS</b>	LKDNext, HFC/HFO, SC 1000 ppm, Built-in, AO, DO, Modbus	HFC/HFO		SC	Type 2 (HFC/HFO)	1,000	
<b>LKDN67SC03BS</b>	LKDNext, HC, SC 4000 ppm, Built-in, AO, DO, Modbus	HC		Type 3. Hydrocarb. refr. (HC)	4,000		
<b>LKDN67EC04BS</b>	LKDNext, NH3, EC 100 ppm, Built-in, AO, DO, Modbus	Ammonia (NH3)		EC	/	100	
<b>LKDN67EC05BS</b>	LKDNext, NH3, EC 1000 ppm, Built-in, AO, DO, Modbus	Ammonia (NH3)		EC	/	1,000	
<b>LKDN67EC06BS</b>	LKDNext, NH3, EC 5000 ppm, Built-in, AO, DO, Modbus	Ammonia (NH3)		EC	/	5,000	
<b>IR</b> Infrared / Infrarosso <b>SC</b> Semiconductor / Semiconduttore <b>EC</b> Electrochemical / Elettrochimica							

LKDNext Reference	Description	Refrigerant	Sensor style	Sensor technology	Sensor type	Operating range [ppm]	Power Supply
<b>LKDN67IR00RS</b>	LKDNext, CO2, IR 10000 ppm, Remote, AO, DO, Modbus	CO2	Remote	IR	/	10,000	24 Vdc ±20%  24 Vac ±20% 50/60 Hz
<b>LKDN67SC01RS</b>	LKDNext, R32mix, SC 1000 ppm, Remote, AO, DO, Modbus	R32 mixtures		Type 1 (R32 mixtures)	1,000		
<b>LKDN67SC02RS</b>	LKDNext, HFC/ HFO, SC 1000 ppm, Remote, AO, DO, Modbus	HFC/HFO		Type 2 (HFC/HFO)	1,000		
<b>LKDN67SC03RS</b>	LKDNext, HC, SC 4000 ppm, Remote, AO, DO, Modbus	HC		Type 3. Hydrocarb. refr. (HC)	4,000		
<b>LKDN67EC04RS</b>	LKDNext, NH3, EC 100 ppm, Remote, AO, DO, Modbus	Ammonia (NH3)		EC	/	100	
<b>LKDN67EC05RS</b>	LKDNext, NH3, EC 1000 ppm, Remote, AO, DO, Modbus	Ammonia (NH3)		EC	/	1,000	
<b>LKDN67EC06RS</b>	LKDNext, NH3, EC 5000 ppm, Remote, AO, DO, Modbus	Ammonia (NH3)		EC	/	5,000	
<b>IR</b> Infrared / Infrarosso <b>SC</b> Semiconductor / Semiconduttore <b>EC</b> Electrochemical / Elettrochimica							

## Gas Detector LKDNext series part numbers Dongle BTLE

LKDNext Reference with Dongle BTLE (1)	Description	Refrigerant	Sensor style	Sensor technology	Sensor type	Operating range [ppm]	Power Supply
LKDN67IR00BSK	LKDNext, CO2, IR 10000 ppm, Built-in, AO, DO, Modbus, BT(1)	CO2	Built-in	IR	/	10,000	24 Vdc ±20%  24 Vac ±20% 50/60 Hz
LKDN67SC01BSK	LKDNext, R32mix, SC 1000 ppm, Built-in, AO, DO, Modbus, BT(1)	R32 mixtures		SC	Type 1 (R32 mixtures)	1,000	
LKDN67SC02BSK	LKDNext, HFC/HFO, SC 1000 ppm, Built-in, AO, DO, Modbus, BT(1)	HFC/HFO			Type 2 (HFC/HFO)	1,000	
LKDN67SC03BSK	LKDNext, HC, SC 4000 ppm, Built-in, AO, DO, Modbus, BT(1)	HC			Type 3. Hydrocarb. refr. (HC)	4,000	
LKDN67EC04BSK	LKDNext, NH3, EC 100 ppm, Built-in, AO, DO, Modbus, BT(1)	Ammonia (NH3)		EC	/	100	
LKDN67EC05BSK	LKDNext, NH3, EC 1000 ppm, Built-in, AO, DO, Modbus, BT(1)	Ammonia (NH3)		EC	/	1,000	
LKDN67EC06BSK	LKDNext, NH3, EC 5000 ppm, Built-in, AO, DO, Modbus, BT(1)	Ammonia (NH3)		EC	/	5,000	
<b>IR</b> Infrared / Infrarosso <b>SC</b> Semiconductor / Semiconduttore <b>EC</b> Electrochemical / Elettrochimica <b>BT</b> Bluetooth							

LKDNext Reference with Dongle BTLE (1)	Description	Refrigerant	Sensor style	Sensor technology	Sensor type	Operating range [ppm]	Power Supply
LKDN67IR00RSK	LKDNext, CO2, IR 10000 ppm, Remote, AO, DO, Modbus, BT(1)	CO2	Remote	IR	/	10,000	24 Vdc ±20% 24 Vac ±20% 50/60 Hz
LKDN67SC01RSK	LKDNext, R32mix, SC 1000 ppm, Remote, AO, DO, Modbus, BT(1)	R32 mixtures		SC	Type 1 (R32 mixtures)	1,000	
LKDN67SC02RSK	LKDNext, HFC/HFO, SC 1000 ppm, Remote, AO, DO, Modbus, BT(1)	HFC/HFO			Type 2 (HFC/HFO)	1,000	
LKDN67SC03RSK	LKDNext, HC, SC 4000 ppm, Remote, AO, DO, Modbus, BT(1)	HC			Type 3. Hydrocarb. refr. (HC)	4,000	
LKDN67EC04RSK	LKDNext, NH3, EC 100 ppm, Remote, AO, DO, Modbus, BT(1)	Ammonia (NH3)		EC	/	100	
LKDN67EC05RSK	LKDNext, NH3, EC 1000 ppm, Remote, AO, DO, Modbus, BT(1)	Ammonia (NH3)		EC	/	1,000	
LKDN67EC06RSK	LKDNext, NH3, EC 5000 ppm, Remote, AO, DO, Modbus, BT(1)	Ammonia (NH3)		EC	/	5,000	
<b>IR</b> Infrared / Infrarosso <b>SC</b> Semiconductor / Semiconduttore <b>EC</b> Electrochemical / Elettrochimica <b>BT</b> Bluetooth							

---

## Sensor module spare part numbers

LKDNext Reference	Description
LKDN67IR00SS	LKDNext, CO2, IR 10000 ppm, spare sensor
LKDN67SC01SS	LKDNext, R32mix, SC 1000 ppm, spare sensor
LKDN67SC02SS	LKDNext, HFC/HFO, SC 1000 ppm, spare sensor
LKDN67EC03SS	LKDNext, HC, SC 4000 ppm, spare sensor
LKDN67EC04SS	LKDNext, NH3, EC 100 ppm, spare sensor
LKDN67EC05SS	LKDNext, NH3, EC 1000 ppm, spare sensor
LKDN67EC06SS	LKDNext, NH3, EC 5000 ppm, spare sensor

## Sensor accessory part number

LKDNext Reference	Description
LKDN67AAAAAB	LKDNext, guarding bracket



---

# CHAPTER 1

## Introduction

---

### 1.1. General Description

The LKDNext series leakage detectors continuously monitor indoor air for any refrigerant leaks. The devices can be used for refrigeration applications (cold rooms, freezer rooms, machinery rooms).

The LKDNext series detectors are available in the following configurations:

- Built-in version
- Remote version

They are calibrated to detect most refrigerants currently available on the market. The sensitive elements are constructed using semiconductor (SC) technology, infrared (IR) technology, or electrochemical (EC) technology. The LKDNext series detectors can be used in stand-alone applications or connected to ELIWELL controllers or third-party devices. Communication with controllers uses an analog output, relays, or an RS485 Modbus serial connection and Bluetooth.

When a refrigerant leakage exceeding a programmable concentration threshold is detected, an alarm or warning status is activated, depending on the level of concentration set, and the LKDNext responds as follows:

- The combination of LEDs that are on changes
- A dedicated internal relay (SPDT) is activated
- Buzzer is activated
- The analog output is controlled (in proportion to the detected concentration)
- The change in status is signalled via the RS485 Modbus output and the Eliwell Air App application

Furthermore, the “Eliwell Air App” app, available in both App Store and Play Store, can be used to access the device.

The LKDNext series detectors enable compliance with refrigeration safety standards (for example EN 378, ASHRAE 15) through alarms to alert personnel in the event of a refrigerant leakage.

The sensitive elements are constructed using semiconductor (SC) technology, infrared (IR) technology, or electrochemical (EC) technology.

SENSOR	TECHNOLOGY	FOR GAS...
<b>with Semiconductor</b>	<b>SC</b>	for refrigerant gases: R32 mixtures, HFO, HC and HFC
<b>with Infrared technology</b>	<b>IR</b>	for CO <sub>2</sub>
<b>Electrochemical</b>	<b>EC</b>	for NH <sub>3</sub>

LKDNext is available in five main versions:

- Semiconductor version for R32 refrigerant gas blends
- Semiconductor version for HC refrigerant gases
- Semiconductor version for HFC/HFO refrigerant gases
- Infrared version for CO<sub>2</sub>
- Electrochemical version for ammonia

Detection of an excessive concentration of gas (above the factory-set limit) results in the transmission of an alarm signal to the supervisor (if connected to the network) and the activation of an on-site acoustic and visual signal. **LKDNext** gas detector ensures a prompt detection of gas leaks thus reducing the risk of machine downtime.

## 1.2. Environmental Characteristics

	Sensor type		
	SEMICONDUCTOR R32, HFO, HC & HFC	ELECTROCHEMICAL NH3	INFRARED CO <sub>2</sub>
The product complies with the following harmonized Standards	<ul style="list-style-type: none"> <li>• (EMC) 2014/30/EU</li> <li>• (LVD) 2014/35/EU</li> <li>• EN61010-1   UL61010-1/CSA C22.2 No. 61010-1               <ul style="list-style-type: none"> <li>• EN 378</li> <li>• EN14624</li> <li>• EN50270</li> <li>• EN50271</li> </ul> </li> </ul>		
IP rating	IP67		
Mounting method	Wall mounting		
Maximum Overall Dimensions	193.9 x 151.2 x 64 mm (7.63 x 5.95 x 2.52 in.)		
Power supply	24 Vac/dc ±20% 50/60 Hz		
Power Consumption	5 W		
Serial communication	Modbus RS485 isolated slaves		
Analog output	1-5 V, 0-10 V, 2-10 V, 4-20 mA		
<b>Digital outputs</b>	<b>2 relays at 1 A 24 Vac/dc</b>		
Digital output 1 SPDT	Alarm - relay 1 A / 24 Vac/dc, resistive load		
Digital output 2 SPDT	Warning/FAULT - relay 1 A/24 Vac/dc, resistive load		
Relay failsafe	Yes, selectable		
Buzzer	YES		
Hysteresis	± 10% of the threshold value		
Selectable alarm delay	0-20 min; 1-minute steps, selectable via Modbus register/App/Service wheel		
Ambient operating conditions	-40 ... 50 °C (-40 ... 122 °F) 5 ... 90 % (non condensing)		
Ambient operating conditions DONGLE models	-20 ... 50 °C (-4 ... 122 °F) 5 ... 90 % (non condensing)		
Transportation and storage conditions	-40 ... 50 °C (-40 ... 122 °F) 5 ... 90 % (non condensing)		
Transportation and storage conditions DONGLE models	-25...50 °C (-13 ... 122 °F) 5 ... 90 % (non condensing)		
Sensing element	Pre-calibrated (also available as a spare part) with certificate		
Remote cable length	5 metres		
Operating Altitude	0...2,000 m (0...6,560 ft)		
Storage Altitude	0...3,000 m (0...9,842 ft)		
Typical operating range	1,000 ppm (HFC/HFO/R32 mixtures) 4,000 ppm (HC)	100 ppm 1,000 ppm 5,000 ppm	10,000 ppm
Operating position	Intended for vertical mounting with the sensor at the bottom		
Storage position	Any		
Precision*	<-10%/+15%	±5%	±5%
Start-up time*	5 minutes	5 minutes	2 minutes
Working sensor life*	5 years	2 years	7 years
Calibration procedure requirements OR sensor substitution	12 months	12 months	Not required

\*Reference conditions at 25°C 50% RH atmospheric pressure 101.3 kPa

\*\*The device is intended to be supplied from an isolated Limited Energy Source per UL61010-1, 3rd edition cl. 9.4 or Limited Power Source per UL60950-1 or Class 2 per NEC

---

## 1.3. Chemicals and gases interference

Interference from chemicals and gases to Semiconductor based gas detectors

### 1.3.1. Background

Gas detectors are designed and calibrated to identify specific gases or a range of gases in an environment, and false alarms can be triggered by various chemicals and gases that the detector is not specifically calibrated to detect or that interfere with its sensors.

### 1.3.2. Common causes of false alarms

Chemicals affecting the performance can be, but are not limited to:

#### 1. Hydrocarbons

- Methane
- Propane
- Butane

#### 2. Alcohols

- Ethanol
- Isopropanol
- Methanol

Alcohols can trigger false alarms in gas detectors designed to detect volatile organic compounds (VOCs) or certain toxic gases.

#### 3. Solvents

- Acetone
- Toluene
- Xylene compounds
- Paints

Solvents are common in industrial, food and laboratory environments and can cause cross-sensitivity in gas detectors.

#### 4. Silicones

- Silicone spray
- Silicone sealant
- Siloxane compounds

Silicone compounds can poison certain sensor types

---

## 5. Volatile Organic Compounds (VOCs) Emissions

- Epoxy resins
- Polyester resins
- Urethane resins

## 6. Cleaning Agents

- Bleach (Sodium Hypochlorite)
- Ammonia-based cleaners
- Chlorine-based disinfectants

These chemicals can cause interference or temporary sensor overloads, leading to false alarms.

## 7. Industrial Gases

- Helium
- Carbon Dioxide (CO<sub>2</sub>)
- Argon

In certain concentrations, these gases can affect the readings of sensors designed for other gases.

## 8. Environmental Contaminants

- Smoke
- Dust
- Humidity

These factors can cause physical or chemical interference with the sensors, leading to false alarms.

## 9. Miscellaneous Chemicals

- Ammonia (NH<sub>3</sub>)
- Hydrogen Sulfide (H<sub>2</sub>S)
- Carbon Monoxide (CO)
- Ozone (O<sub>3</sub>)
- R-1234ze (C<sub>3</sub>F<sub>4</sub>H<sub>2</sub>)
- R-1233000zde (C<sub>3</sub>ClF<sub>3</sub>H<sub>2</sub>)
- Lead (Pb), sulphur (S) or phosphorus (P) based compounds

## How to Mitigate False Alarms

- Regular Calibration and Maintenance: Ensure detectors are regularly calibrated to the specific gases they are intended to detect.
- Environmental Control: Minimize the presence of interfering substances in areas where gas detectors are deployed.
- Sensor Selection: Use the appropriate sensor type for the environment and specific gas detection requirements.
- Use of Filters: Employ filters to reduce the impact of dust, humidity, and other contaminants.
- Training: Ensure personnel are trained to recognize and manage potential sources of false alarms.

## 1.4. Annual Test

According to the manufacturer and as indicated by the F-Gas regulation, it is suggested to test the sensor at least once a year.

In case of application of particularly heavy usage environment you may require more frequent inspections.

However, local regulations may specify the nature and frequency of this test.

Visual inspection:

1. Check the conditions of the enclosure.
2. Verify the presence of cable glances and cups inside them.
3. Confirm that the sensor module enclosure is in good condition.

## Test mode (through Eliwell Air App or Modbus commands)

Procedure	Modbus register	Eliwell Air App Command/Parameter (1)	Result
Activate "Test mode"	820	"TEST_ON"	Green NORMAL LED deactivated
Check relay output 1	800	"RL1_ON" / "RL1_OFF"	Relay RL1 will change status
Check relay output 2	801	"RL2_ON" / "RL2_OFF"	Relay RL2 will change status
Check LED (ALARM)	803	"LEDR_ON" / "LEDR_OFF"	Red (ALARM) LED activated / Red (ALARM) LED deactivated
Check LED (NORMAL)	804	"LEDG_ON" / "LEDG_OFF"	Green (NORMAL) LED activated / Green (NORMAL) LED deactivated
Check LED (WARNING)	805	"LEDY_ON" / "LEDY_OFF"	Yellow (WARNING) LED activated / Yellow (WARNING) LED deactivated
Check buzzer	410	"BUZ_ON" / "BUZ_OFF"	Buzzer activated / Buzzer deactivated
Check analog output	605	"AO_Val"	Change value and measure analog output
Finish service	401	"SER_OK"	Write 0 to conform service done
Deactivate "Test mode"	820	"TEST_OFF"	Green NORMAL LED activated

(1) see "5.8.1. Parameters Address" on page 55 and "5.8.2. Resources Address" on page 56

## Gas concentration inspection and sensor replacement request

During the gas concentration inspection and sensor replacement request, follow these steps:

1. Verify the value of concentration by checking the GCon register (register 101).
2. If SER (register 401) equals 1, proceed with the following actions based on the type of sensor:
  - a. For infrared (IR) sensors: conduct a visual inspection and perform the Test Mode procedure.
  - b. For semiconductor (SC) and electrochemical (EC) sensors: conduct a visual inspection, change the sensor, and perform the Test Mode procedure.

These steps help ensure that the gas concentration is accurately measured and, if necessary, sensors are replaced to maintain proper functionality.

---

## 1.5. Disposal of the device

### 1.5.1. Disposal of electrical and electronic equipment

Since August 2012, rules governing the disposal of electrical and electronic equipment defined in European Directive 2012/19/ EU (WEEE) and national laws, which apply to this device, have been in force throughout the European Union. Common household appliances can be disposed of via special collection and recycling sites. However, this device has not been registered for home use. Therefore, it must not be disposed of using these services. Do not hesitate to contact ELIWELL if you have any further questions on this topic.

### 1.5.2. Disposal of the sensors

Dispose of the sensors in accordance with local laws.

#### **DANGER**

##### **POTENTIAL FOR EXPLOSION**

Do not throw the sensors into fire.

**Failure to follow these instructions will result in death or serious injury.**

#### **DANGER**

##### **HAZARD OF CHEMICAL BURNS**

Do not force open the electrochemical sensors.

**Failure to follow these instructions will result in death or serious injury.**

Observe local regulations regarding waste disposal. For information, contact your local environmental agency, local government offices or appropriate waste disposal services

#### **WARNING**

##### **REGULATORY INCOMPATIBILITY**

Ensure that all equipment applied and systems designed comply with all applicable local, regional, and national regulations and standards.

**Failure to follow these instructions can result in death, serious injury, or equipment damage.**

---

## CHAPTER 2

### Mechanical installation

---

#### 2.1. Before Starting

Read this manual carefully before installing the device and its accessories.

In particular, ensure conformity with all safety indications, electrical requirements and current legislation for the machine or the process used with this equipment.

The use and application of information contained herein requires experience in the design and programming of automated control systems. Only the machine user, integrator or manufacturer will be aware of all the conditions and factors affecting installation, configuration, operation and maintenance of the machine or process and can therefore identify the associated equipment and corresponding safety interlocks and systems that can be used appropriately and efficiently. When selecting automation and control equipment, other equipment and connected software for a particular application, all local, regional and national standards and/or legislation must be taken into account.

#### **WARNING**

##### **REGULATORY INCOMPATIBILITY**

Ensure that all equipment applied and systems designed comply with all applicable local, regional, and national regulations and standards.

**Failure to follow these instructions can result in death, serious injury, or equipment damage.**

#### 2.2. Disconnecting Power

Assemble and install all optional extras and modules before installing the control system on an assembly rail, panel door or other assembly surface.

Before dismantling the equipment, remove the control systems from the assembly rail, plate or panel.

#### **DANGER**

##### **HAZARD OF ELECTRIC SHOCK, EXPLOSION OR ARC FLASH**

- Disconnect all power from all equipment including connected devices prior to removing any covers or doors, or installing or removing any accessories, hardware, cables, or wires.
- Always use a properly rated voltage sensing device to confirm the power is removed.
- Replace and secure all covers, accessories, hardware, cables, and wires and confirm that a proper ground connection exists before applying power to the unit.
- Use only the specified voltage when operating this equipment and any associated products.

**Failure to follow these instructions will result in death or serious injury.**

## 2.3. Operating Environment

This device is not designed to ensure intrinsic safety when used in areas classified as hazardous.

### **DANGER**

#### **POTENTIAL FOR EXPLOSION**

Do not use the device in hazardous locations (classified as such). <sup>(1)</sup>

**Failure to follow these instructions will result in death or serious injury.**

<sup>(1)</sup> For more information see "Directive 2014/34/EU ATEX" and "NFPA 70, Hazardous Location".

### **WARNING**

#### **UNINTENDED EQUIPMENT OPERATION**

Install and operate this equipment according to the conditions described in the Environmental and electrical characteristics.

**Failure to follow these instructions can result in death, serious injury, or equipment damage.**

## 2.4. Installation Considerations

### **WARNING**

#### **UNINTENDED EQUIPMENT OPERATION**

- Use appropriate safety interlocks where personnel and/or equipment hazards exist.
- Install and operate this equipment in an enclosure appropriately rated for its intended environment and secured by a keyed or tooled locking mechanism.
- Power line and output circuits must be wired and fused in compliance with local and national regulatory requirements for the rated current and voltage of the particular equipment.
- Do not use this equipment in safety-critical machine functions unless the equipment is otherwise designated as functional safety equipment and conforming to applicable regulations and standards.

**Failure to follow these instructions can result in death, serious injury, or equipment damage.**

The **LKDNext** devices are intended for wall mounting.

Care must be taken to avoid damage from electrostatic sources when handling this equipment. In particular exposed connectors and, in some cases, exposed printed circuit boards are vulnerable to electrostatic discharge.

### **WARNING**

#### **UNINTENDED EQUIPMENT OPERATION DUE TO ELECTROSTATIC DISCHARGE DAMAGE**

- Only install equipment in approved enclosures and / or locations that prevent unauthorized access and provide electrostatic discharge protection.
- Use a conductive wrist strap or equivalent field force protective device attached to an earth ground when handling sensitive equipment.
- Always discharge yourself by touching a grounded surface or approved antistatic mat before handling the equipment.

**Failure to follow these instructions can result in death, serious injury, or equipment damage.**

### **CAUTION**

#### **INOPERABLE EQUIPMENT**

Do not expose installation surfaces to continuous vibrations.

**Failure to follow these instructions can result in equipment damage.**



## 2.5. Mounting of LKDNNext

The mechanical mounting varies depending on the version which is being installed (Built-in or remote versions). There are no different mounting instructions for semi-conductor and IR models except for their positioning inside the room to be monitored, which depends on the specific behavior of the monitored gas.

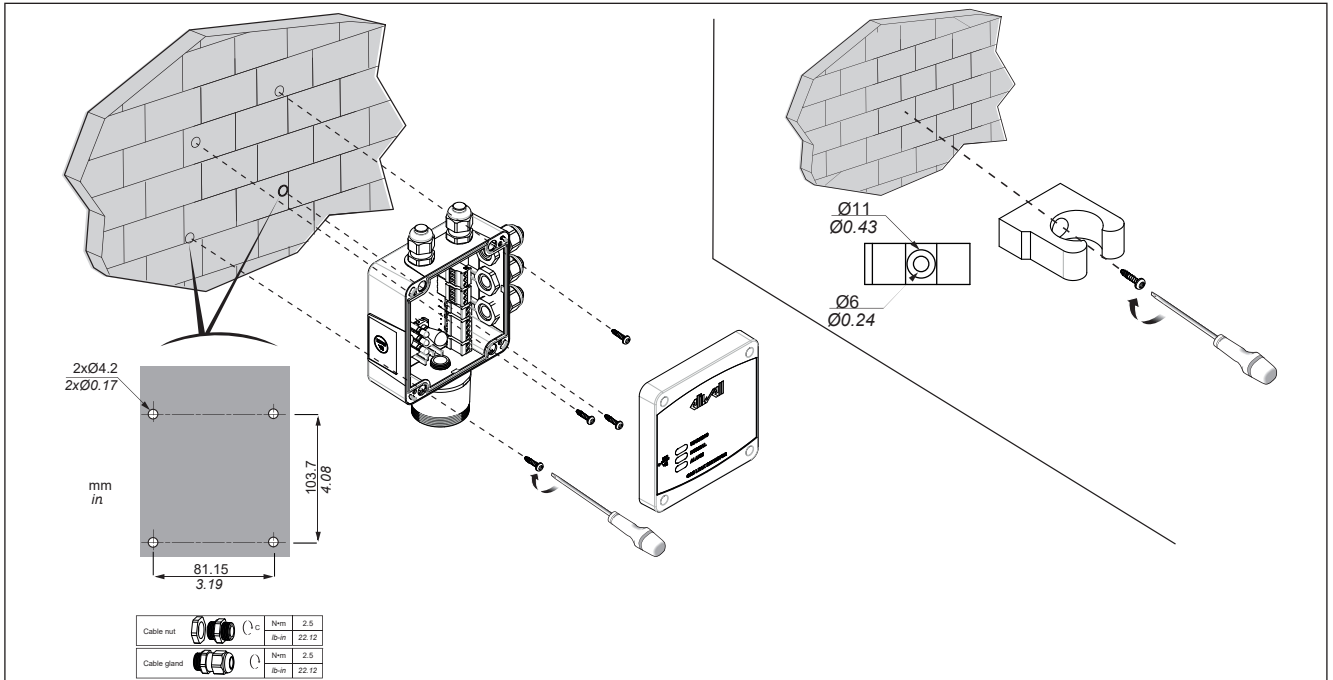

Fig. 1. LKDNNext Mounting

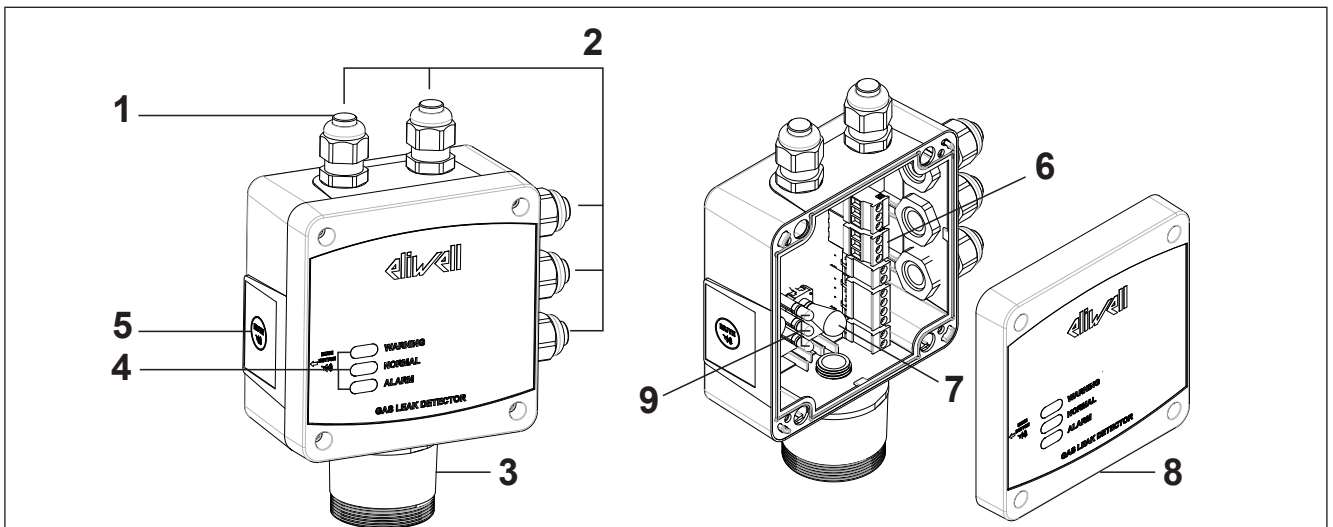

Fig. 2. LKDNNext Components

1. Cap
2. Cable glands
3. Sensor probe (Built-in models)
4. LEDs
5. Reset/Mute button
6. Terminals
7. Service Wheel
8. Front cover
9. Internal LEDs

## 2.6. LKDNext Dimensions

### 2.6.1. Built-in models dimensions

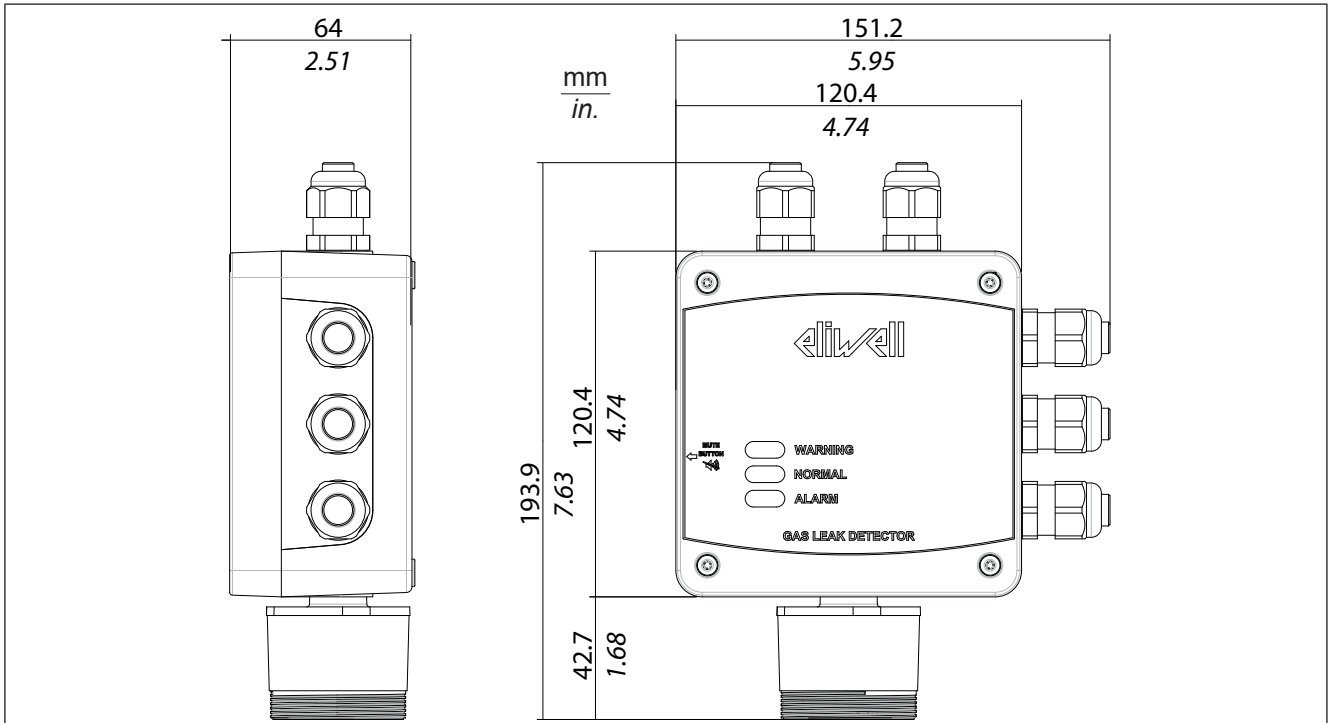

Fig. 3. LKDNext Dimensions with Built-In sensor

### 2.6.2. Remote version dimensions

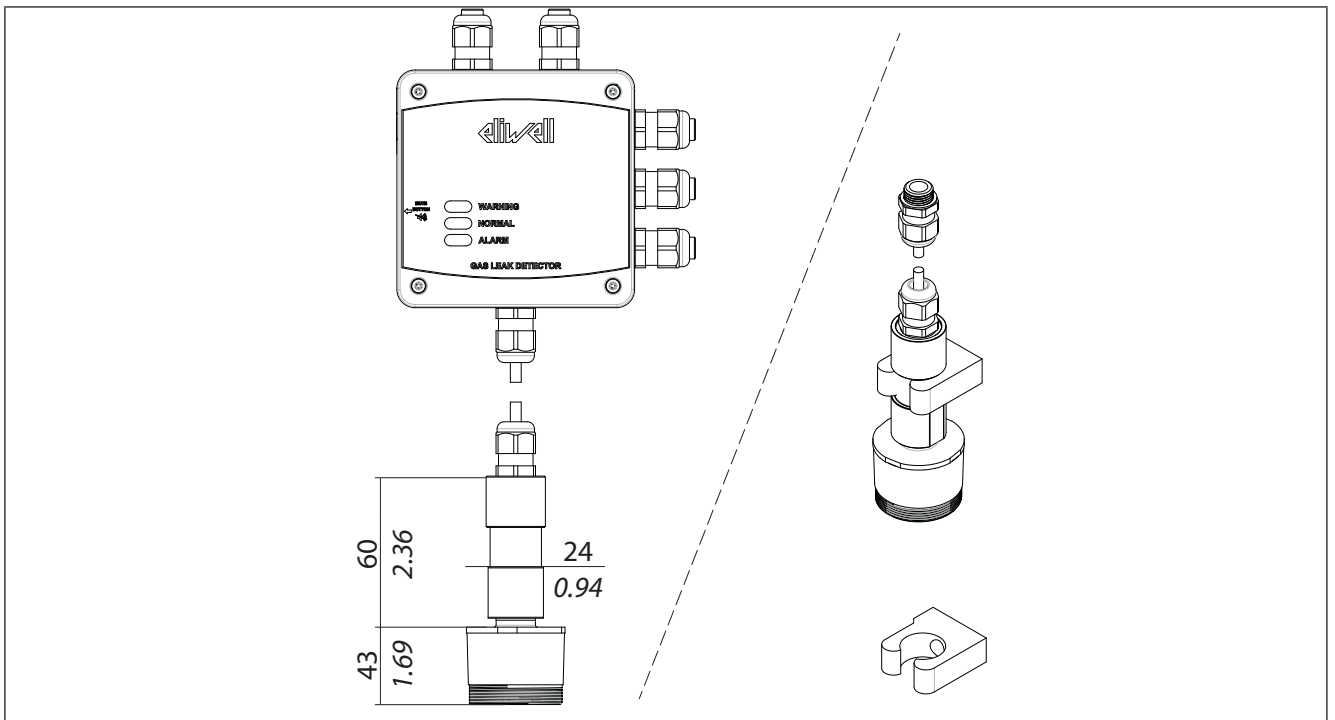
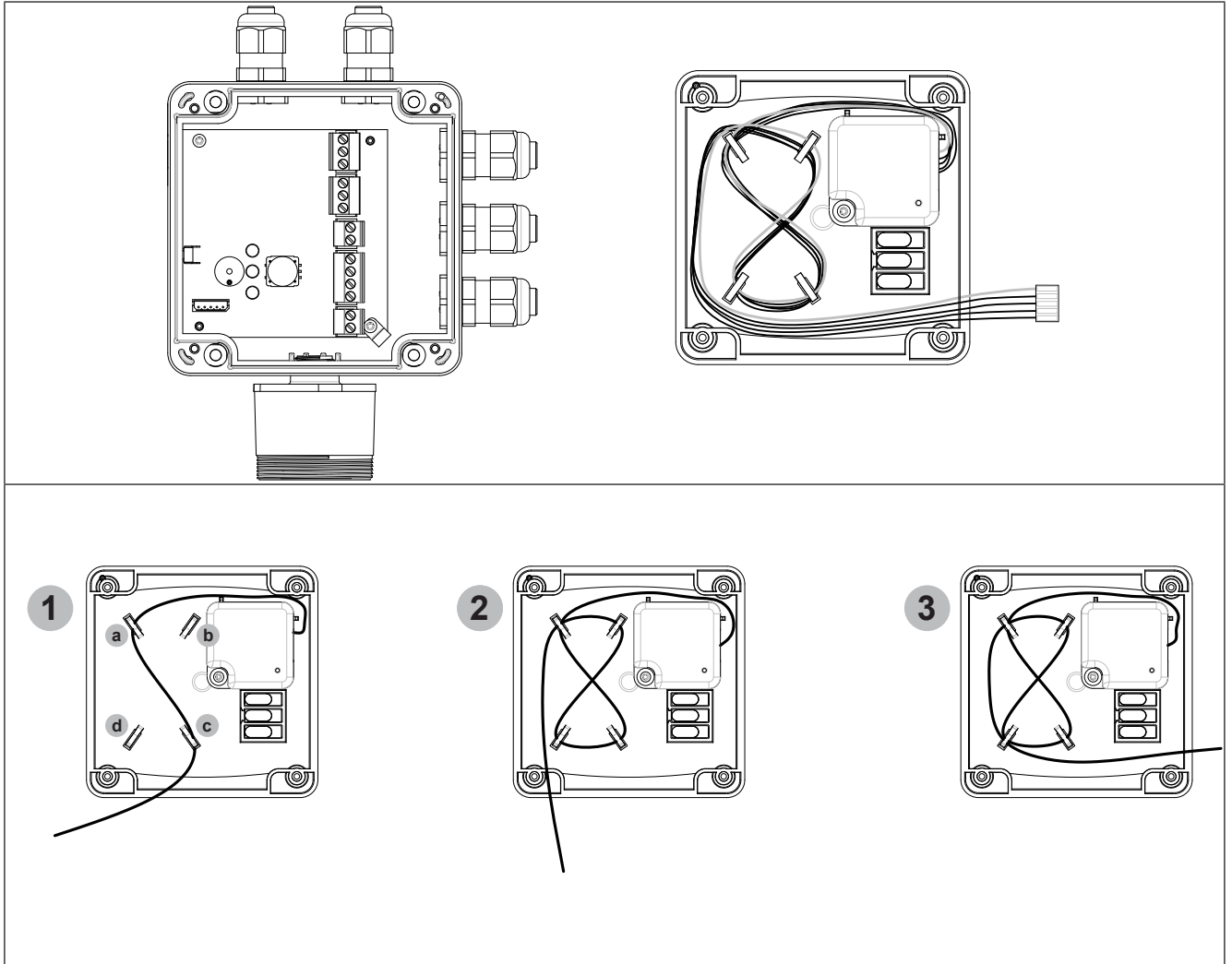

Fig. 4. LKDNext Dimensions with Remote sensor

## 2.7. Installation

### 2.7.1. Mounting LKDNext with DONGLE



**Fig. 5. LKDNext Dongle Mounting**

- Open the cover of the LKDNext with proper torque
- Fix the dongle using one screw, maximum diameter 7 mm, minimum length 15 mm and torque 1.7 Nm <sup>(1)</sup>.
- Wrap the TTL cable as suggested in the figure above:
  1. Wrap the TTL cable using the clips a) and c)
  2. Wrap the TTL cable using the clips d) and b) making an eyelet
  3. Wrap the TTL cable using the clips a) and d)

<sup>(1)</sup>To mount the dongle use screw available in the package.

(Package includes nr. 1x Button head Pozidriv PZ, Thread size (metric): 3, steel).

Do not use tightening torques greater than those indicated

## 2.7.2. Mounting LKDNext with protection bracket

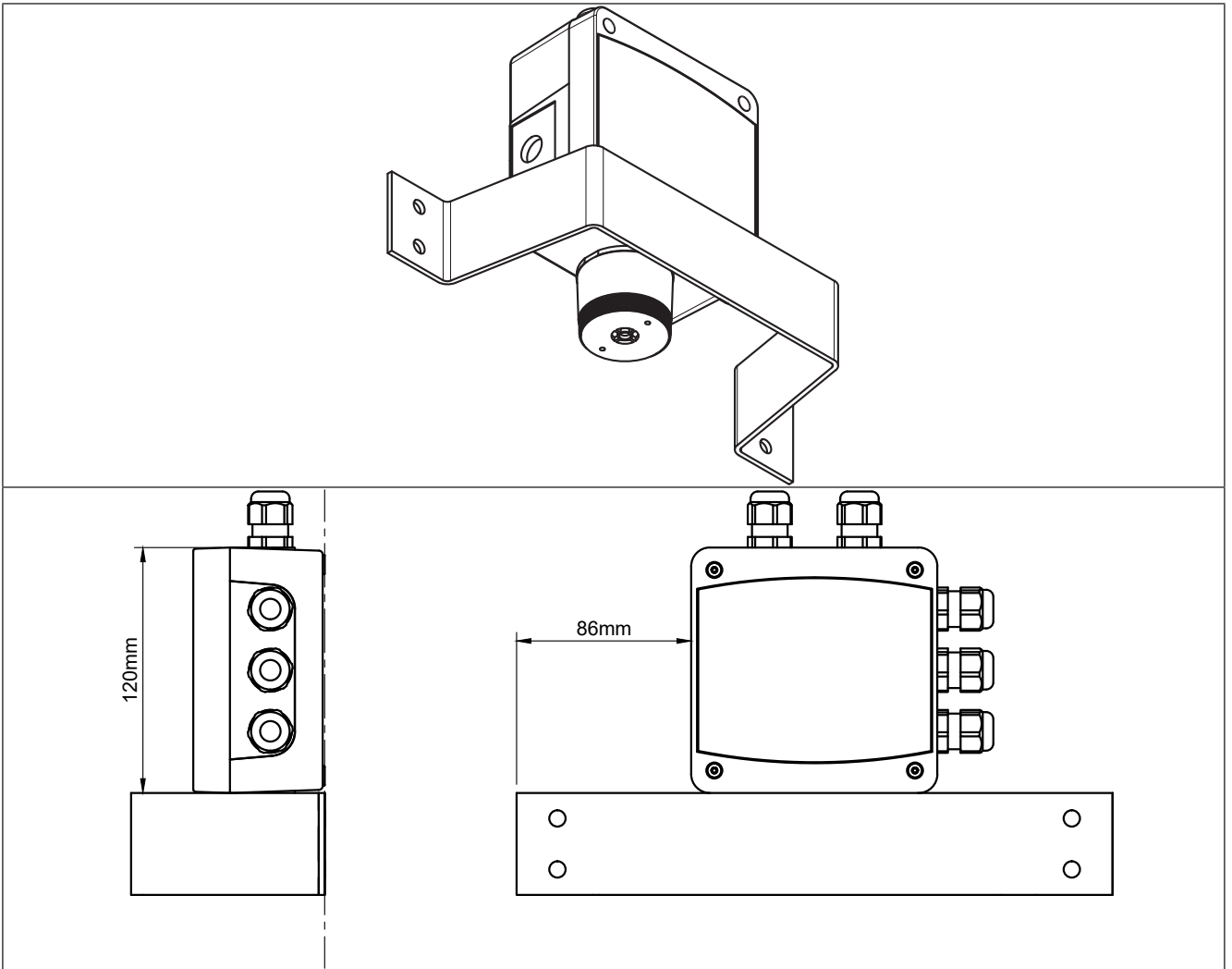
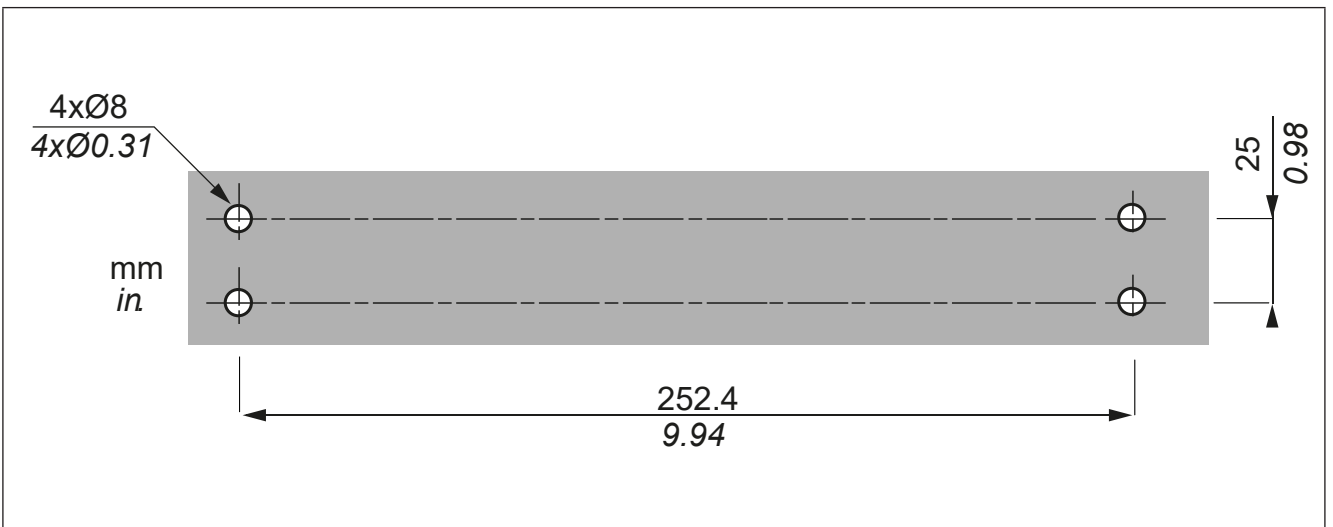

Fig. 6. LKDNext Protection bracket



Use 6 mm (0.23 in.) diameter screws and tighten to 8.5 Nm (75.23 lb-in.)

Fig. 7. LKDNext Protection bracket Drilling template

### 2.7.3. Eliwell AIR App

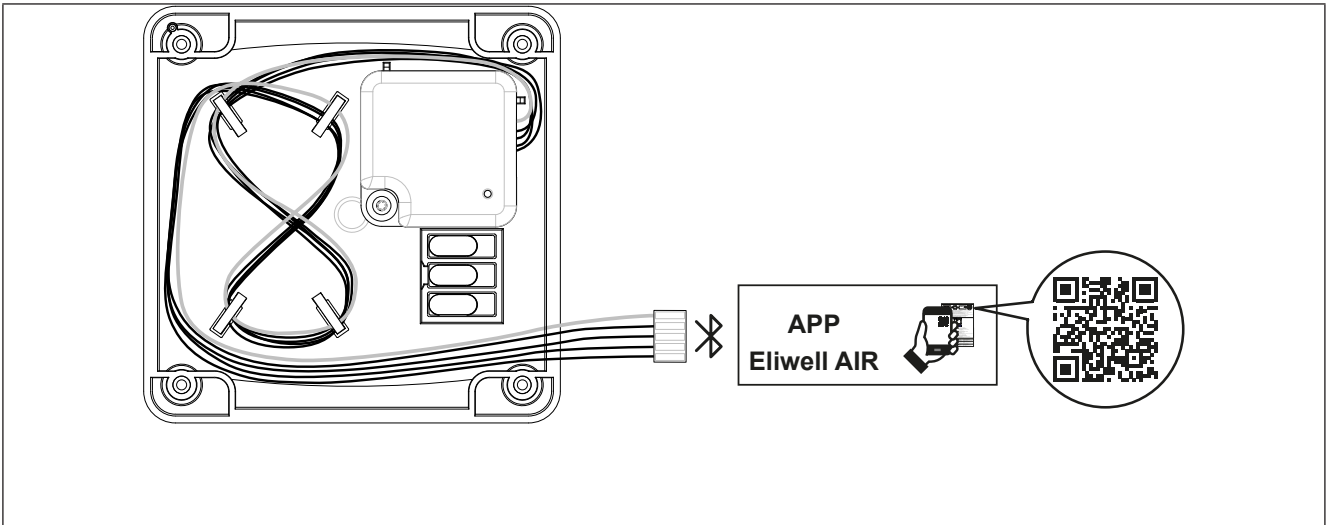

Fig. 8. LKDNext & Eliwell AIR App

### 2.7.4. Correct Mounting Position

LKDNext must be mounted horizontally on a vertical plane or horizontally upward as shown in the figure below:

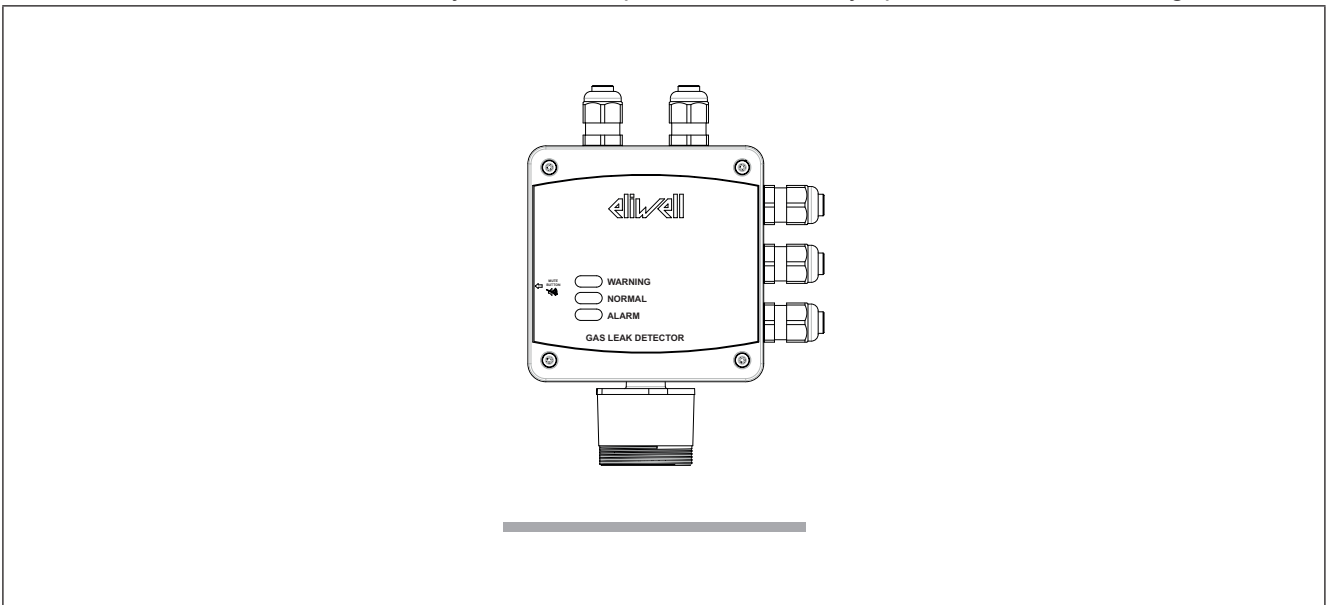

Fig. 9. Correct Mounting Position

### 2.7.5. Incorrect Mounting Position

LKDNext cannot be mounted neither vertically, nor horizontally backward:

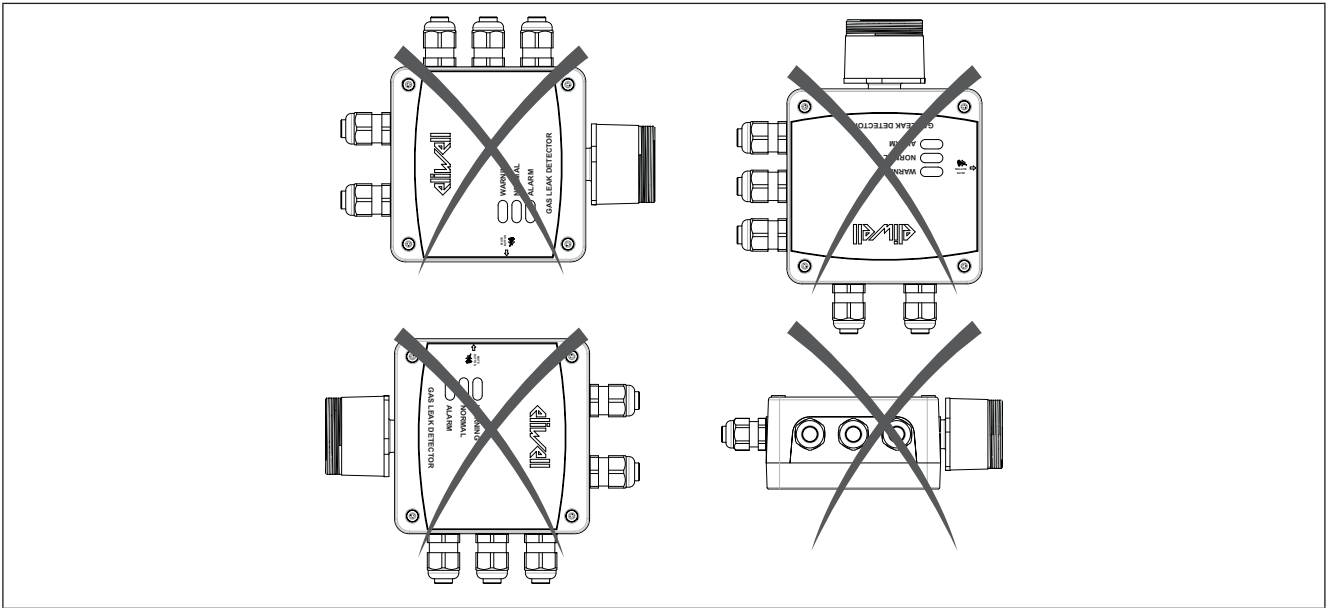

Fig. 10. Incorrect Mounting Position

### 2.7.6. Minimum Clearances

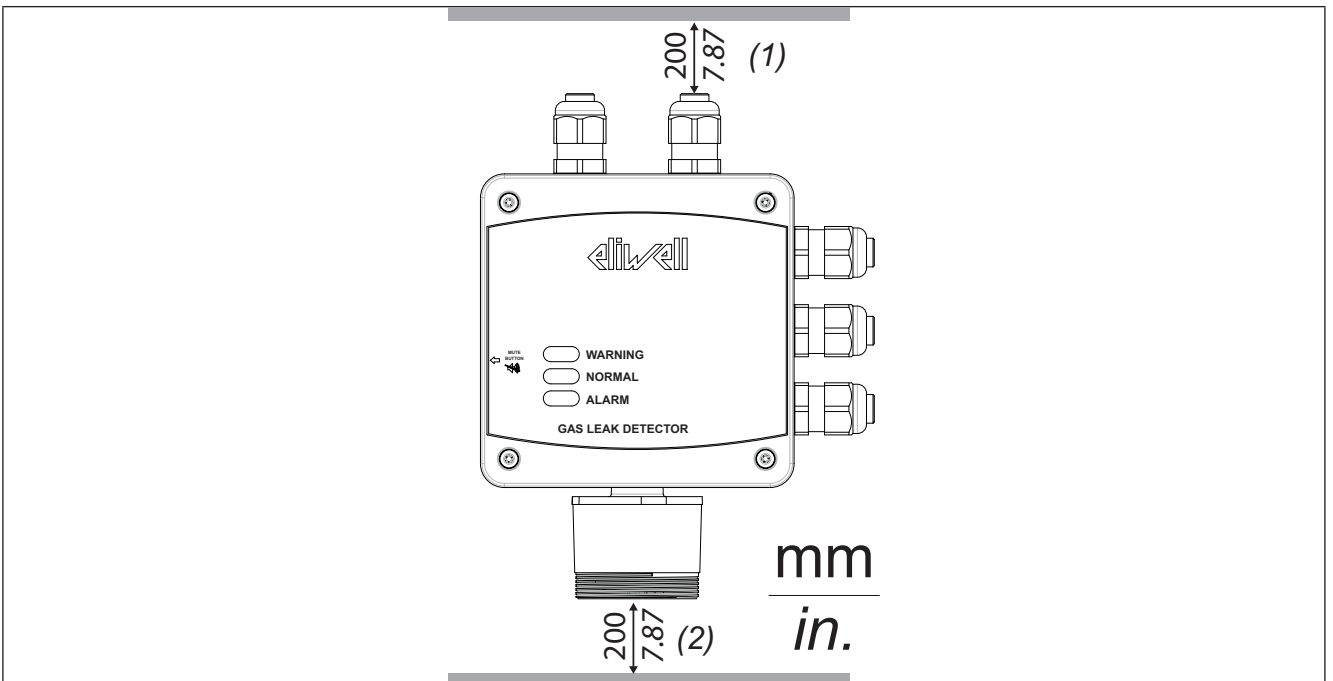

Fig. 11. Minimum Clearances

	Refrigerant Type	Mounting height
(1)	NH3 Ammonia (R-717)	20 cm below ceiling
(2)	HFC / HFO / C3 H8 Propane (R290)	20 cm above the floor
	CO2 Carbon Dioxide (R744)	20 cm above the floor

---

## CHAPTER 3

### Installation and Maintenance

---

#### 3.1. Location instruction

Refrigerant Type	Mounting height
NH3 Ammonia (R-717)	20 cm below ceiling
HFC / HFO / C3 H8 Propane (R290)	20 cm above the floor
CO2 Carbon Dioxide (R744)	20 cm above the floor

##### 3.1.1. Location of sensors

THERE IS NO GENERAL RULE for establishing the appropriate number of sensors and their location for each application. Therefore, the guidelines described below are intended as support for installers, and not as rules in their own right. ELIWELL accepts no liability for the installation of the gas detectors.

Sensors must be located within the appropriate wire lengths from the central control unit (if used).

In all cases the sensor supplied is designed for maximum sensitivity to a particular gas (for example: R134a, NH3, R290, etc.).

However, in certain circumstances, false alarms may be caused by the occasional presence of sufficiently high concentrations of other gaseous impurities.

If such a situation is likely to arise installers should check that sensor (s) of suitable cross sensitivity can be supplied.

Examples of situations where such abnormalities may arise include:

- Plant room maintenance activity involving solvent or paint fumes or refrigerant leaks.
- Plant rooms in fruit ripening/storage facilities because of accidental gas migration (bananas - ethylene, apples - carbon dioxide)
- Heavy localized exhaust fumes (carbon monoxide, dioxide, propane) from engine driven forklifts in confined spaces or close to sensors.

A response delay may be selected to minimise any problems that might arise.

---

### 3.1.2. Equipment rooms

In equipment rooms, the gas detectors can be installed as follows:

- Position the gas detectors near areas with a high concentration of refrigerant, such as compressors, cylinders, storage tanks, pipes and conduits. Avoid vibrating surfaces.
- Position the gas detectors near mechanical parts such as pressure reducers, valves, flanges, joints (brazed or mechanical) and pipes. In particular, above or below these in relation to the type of gas (see below).
- Position the gas detectors around the perimeter of the room, so as to completely surround the equipment.
- Position the gas detectors in all enclosed areas (stairwells, pits, enclosed corners, etc.) where pockets of stagnant gas may form.
- Position the gas detectors near ventilation air flows, both natural and mechanical (if present).
- Do not place the gas detectors too close to areas with high-pressure gas, to allow this to spread in the space around the gas detector. Otherwise the device may not detect the refrigerant leak if the flow of gas is too fast.

### 3.1.3. Cold rooms

In cold rooms, position the gas detectors near the return air flow from the evaporator, ideally on a side wall, but not directly in front of the evaporator.

Where there are several evaporators, it may be possible to use one gas detector for every two evaporators, if their positioning allows.

Finally, position the gas detectors near mechanical parts or joints such as valves, flanges and pipes, avoiding areas with high-pressure gas.

### 3.1.4. Chillers

Measuring leaks on outdoor chillers is generally more difficult, given the highly variable air flow.

Generally, it is recommended to install the gas detectors near the compressor, as this is the place where refrigerant leaks are most likely to occur. In particular, check if it is possible to install the gas detector inside the closed unit near the compressor, where gas is more likely to stagnate. However, avoid vibrating surfaces or surfaces that are difficult to access for maintenance.

It is also recommended to install gas detectors along the ventilation system, especially in the event of low or variable air flow speeds.

### 3.1.5. Air Conditioning - Direct systems VRF/VRV

In air-conditioned buildings, it is recommended to install at least one gas detector in each room, identifying the areas of greatest risk, such as air flows from ventilation systems and heating systems such as radiators.

In these spaces, the refrigerant gas is usually denser than air: consequently, the gas detectors should be installed close to the floor.

Also consider installing the gas detector in ceilings or false ceilings, if not adequately sealed. Do not install the gas detectors underneath mirrors/washbasins and inside bathrooms.

Do not install the gas detectors near sources of steam.



---

## CHAPTER 4

### Connections and configurations

---

#### 4.1. Wiring Best Practices

The following information describe the wiring guidelines and associated best practices to be respected when using the LKDNext.

#### **DANGER**

##### **HAZARD OF ELECTRIC SHOCK, EXPLOSION OR ARC FLASH**

- Disconnect all power from all equipment including connected devices prior to removing any covers or doors, or installing or removing any accessories, hardware, cables, or wires.
- Always use a properly rated voltage sensing device to confirm the power is removed.
- Replace and secure all covers, accessories, hardware, cables, and wires and confirm that a proper ground connection exists before applying power to the unit.
- Use only the specified voltage when operating this equipment and any associated products.

**Failure to follow these instructions will result in death or serious injury.**

#### 4.1.1. Wiring Guidelines

The following rules must be applied when wiring an **LKDNext Leak Detector**:

- Make connections as short as possible and do not wind them around electrically connected parts.
- Verify that the operating conditions and environment are within the specification values.
- Use proper wire sizes to meet voltage and current requirements.
- Use copper conductors (required).

#### **WARNING**

##### **UNINTENDED EQUIPMENT OPERATION**

- Use twisted pair, shielded cables for all, analog I/O and communication signals <sup>(1)</sup>.
- Ground cable shields for all analog I/O and communication signals at a single point <sup>(1)(2)</sup>.
- Route communication and I/O cables separately from power cables.







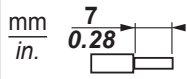

**Failure to follow these instructions can result in death, serious injury, or equipment damage.**

<sup>(1)</sup> If you do not use shielded cable for these connections, electromagnetic interference can cause signal degradation. Degraded signals can cause the controller or attached modules and equipment to perform in an unintended manner.



<sup>(2)</sup> Multipoint grounding is permissible if connections are made to an equipotential ground plane dimensioned to help avoid cable shield damage in the event of power system short-circuit currents.

### 4.1.2. Rules for Removable Screw Terminals Block

The following table presents the cable types and wire sizes for a **5.08** or **5.00** pitch removable screw terminals block:

								
mm in.	mm <sup>2</sup>	AWG	mm <sup>2</sup>	mm <sup>2</sup>	mm <sup>2</sup>	mm <sup>2</sup>	mm <sup>2</sup>	mm <sup>2</sup>
$\frac{7}{0.28}$	0.2...2.5	24...14	0.2...2.5	0.25...2.5	2 x 0.2...1	2 x 0.2...1.5	2 x 0.25...1	2 x 0.5...1.5
			24...14	24...14	2 x 24...18	2 x 24...18	2 x 24...18	2 x 20...16

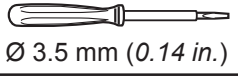
		N•m	0.5...0.6
Ø 3.5 mm (0.14 in.)		lb-in	4.42...5.31

**Fig. 12.** Pitch 5.08 mm (0.20 in.) or 5.00 mm (0.197 in.)

The use of copper conductors is required.

#### **DANGER**

##### **LOOSE WIRING CAUSES ELECTRIC SHOCK**

- Tighten connections in conformance with the torque specifications.
- Do not insert more than one wire per connector of the terminal block unless using the cable ends (ferrules) specified above.

**Failure to follow these instructions will result in death or serious injury.**

#### **DANGER**

##### **FIRE HAZARD**

Use only the correct wire sizes for the current capacity of the I/O channels and power supplies.

**Failure to follow these instructions will result in death or serious injury.**

#### **WARNING**

##### **UNINTENDED EQUIPMENT OPERATION**

Signal cables (communication, and related power supplies), power and device power cables must be routed separately.

**Failure to follow these instructions can result in death, serious injury, or equipment damage.**

---

### 4.1.3. Special Handling Considerations

#### **⚠ WARNING**

##### **UNINTENDED EQUIPMENT OPERATION**

- Use appropriate safety interlocks where personnel and/or equipment hazards exist.
- Install and operate this equipment in an enclosure appropriately rated for its intended environment and secured by a keyed or tooled locking mechanism.
- Power line and output circuits must be wired and fused in compliance with local and national regulatory requirements for the rated current and voltage of the particular equipment.
- Do not use this equipment in safety-critical machine functions.

**Failure to follow these instructions can result in death, serious injury, or equipment damage.**

The **LKDNext** devices are intended for wall mounting.

Care must be taken to avoid damage from electrostatic sources when handling this equipment. In particular exposed connectors and, in some cases, exposed printed circuit boards are vulnerable to electrostatic discharge.

#### **⚠ WARNING**

##### **UNINTENDED EQUIPMENT OPERATION DUE TO ELECTROSTATIC DISCHARGE DAMAGE**

- Only install equipment in approved enclosures and / or locations that prevent unauthorized access and provide electrostatic discharge protection.
- Use a conductive wrist strap or equivalent field force protective device attached to an earth ground when handling sensitive equipment.
- Always discharge yourself by touching a grounded surface or approved antistatic mat before handling the equipment.

**Failure to follow these instructions can result in death, serious injury, or equipment damage.**

### 4.1.4. Additional installation notes

Before commencing electrical installation and wiring, carefully read the following notes:

- Power must be supplied by a safety isolation transformer (Class 2) with no earth connection on the secondary winding.
- The cable for the relays must be sized and fitted with fuses based on the rated voltages, currents and environmental conditions.
- If stranded wires are used, it is recommended to use an end terminal
- To comply with RFI immunity regulations, the communication cable shield on the supervisor must be earthed (for example to the chassis, earth bar, etc.)
- Complete all wiring before powering on.

## 4.1.5. Electrical Connections Built-in and remote models

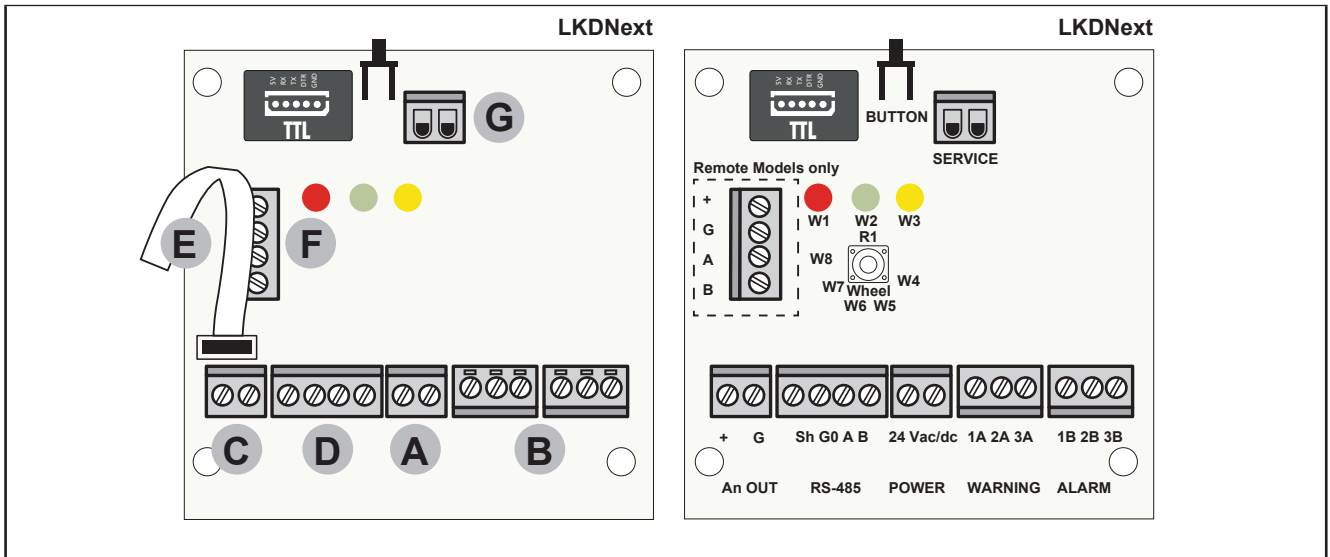
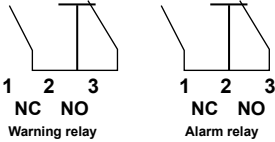
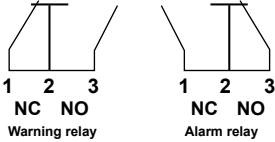
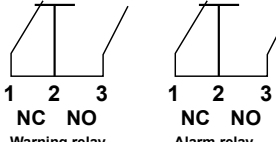
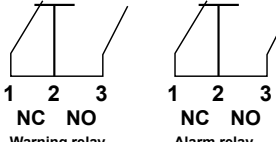

Fig. 13. Electrical connections

<b>An Out</b>	+ G	<b>C</b>	Analog output Analog output reference	
<b>RS 485</b>	Sh G0 A B	<b>D</b>	Shielded RS485 cable GND for RS485 Tx + / Rx + for RS485 Tx- / Rx- for RS485	
<b>POWER</b>	24 Vac/dc	<b>A</b>	For Vac power supply, connect the second transformer wire For Vdc power supply, connect one of the two power wires, the device automatically recognizes whether this is + or GND. For AC power supply, connect one of the two transformer wires.	
<b>WARNING</b>	1A 2A 3A	<b>B</b>	NC contact for the warning/fault relay Common for the warning/fault relay NO contact for the warning/fault relay	NOTE: Valid only for non-powered or non-failsafe state.
<b>ALARM</b>	1B 2B 3B	<b>B</b>	NC contact for the alarm relay Common for the alarm relay NO contact for the alarm relay	
<b>TTL</b>			BTLE Dongle Connector Button	
	+ G	<b>G</b>	V+ for the output voltage provided for service Service voltage reference	
		<b>E</b>	Built-in version sensor connector	
	+/G/A/B	<b>F</b>	Remote version sensor connector (connection not to be used for built-in products)	

## Failsafe Mode

Failsafe mode ACTIVE. Modbus register 403 (FSR) = 0

Concentration: Below Warning Level (WAL) Device: Power ON	Concentration: Above Warning Level (WAL), below Alarm (HAL) Device: Power ON	Concentration: Above Warning Level (WAL), above Alarm (HAL) Device: Power ON	Concentration: NA Device: Power OFF
			

Failsafe mode DEACTIVE. Modbus register 403 (FSR) = 1

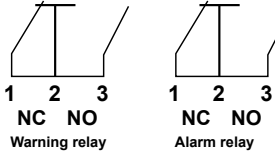
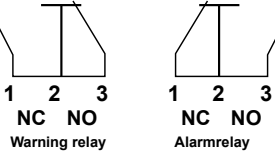
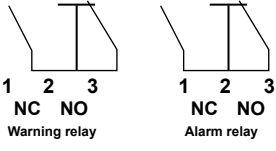
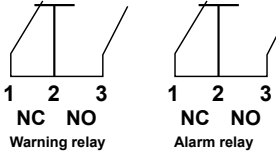
Concentration: Below Warning Level (WAL) Device: Power ON	Concentration: Above Warning Level (WAL), below Alarm (HAL) Device: Power ON	Concentration: Above Warning Level (WAL), above Alarm (HAL) Device: Power ON	Concentration: NA Device: Power OFF
			

## Analog output

The LKDNext series gas detectors feature a single configurable analog output. During normal operation, the device's analog output signal is proportional to the gas concentration measured, and can be selected from the following options:

- 1 to 5 V
- 2 to 10 V
- 0 to 10 V
- 4 to 20 mA (default)

The LKDNext series gas detectors use different voltage/current values to indicate different operating modes. In normal operation, the gas concentration is indicated by the analog output signal level. The relationship between output signal level and gas concentration is shown below:

Analog output range		Gas concentration				
Signal	Notes	0%	50%	100%	Underrange	Overrange
1 to 5 V	-	1 V	3 V	5 V	-	-
2 to 10 V	-	2 V	6 V	10 V	-	-
0 to 10 V	-	0 V	5 V	10 V	-	-
4 to 20 mA	default	4 mA	12 mA	20 mA	2 mA	22 mA

## 4.2. Cable glands

LKDNext is provided with glands loose. IP degree depends on proper installation.

### ⚠ WARNING

#### IP DEGREE LOST

- Install and operate this equipment according to the conditions described in the Environmental and electrical characteristics.
- Verify presence and correct position of cable glands gasket and relevant caps.
- Only use screws provided with the package to close the lid.
- Tighten screws in conformance with the torque specifications.

**Failure to follow these instructions can result in death, serious injury, or equipment damage.**

## 4.3. Built-in and remote models

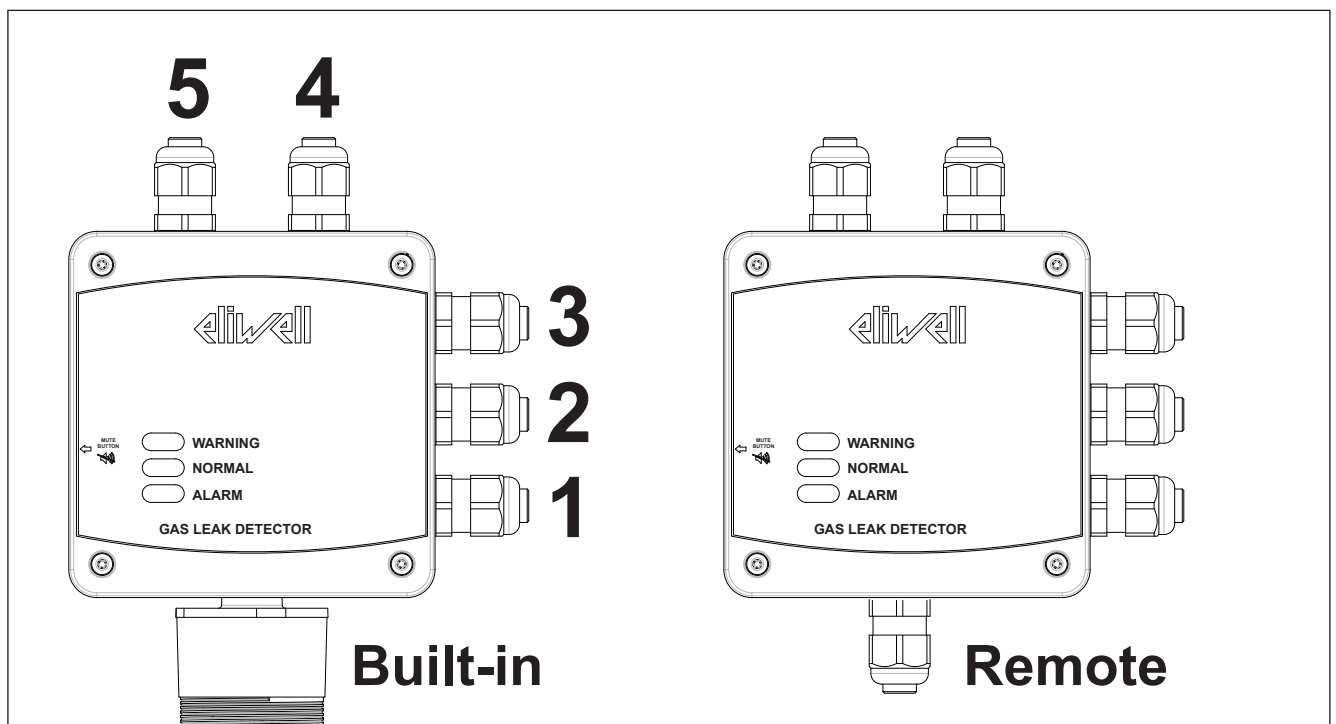

Fig. 14. LKDNext

Once the optimal position to install the sensor has been chosen, it is recommended to install the sensor (identifiable on the device by the black sensor housing) in a vertical position, with the sensitive element (black part) facing downwards. The sensor can now be mounted on the wall, as follows:

- Drill the holes in the wall using the measures on the back side of the detector (shown in the picture below).
- Fix the device using four screws, chosen according to the type of installation and the type of wall <sup>(1)</sup>, maximum diameter 3.5 mm, minimum length 22 mm and torque 1.7 Nm.
- Fix the remote sensor on the wall with the supplied pipe clamp using one screw, chosen according to the type of installation and the type of wall, maximum diameter 4 mm, minimum length 15 mm and torque 2.5 Nm.
- Open the cover of the LKDNext with proper torque, fit the cable glands and make the required electrical connections. The plug-in terminals can be removed from the device to facilitate wiring.

<sup>(1)</sup> To mount enclosure on the wall use screws available in the package.

(Package includes nr. 4x pan head self-tapping screw, zinc coated, steel, DIN7981, Ø3,5X22, H2 recessed head). For other applications, use appropriate screws with diameter and thread no larger than the nominal ones indicated. Do not use tightening torques greater than those indicated.

The following table presents the proper torque for cable glands:

Cable nut		N•m	2.5
		lb-in	22.12
Cable gland		N•m	2.5
		lb-in	22.12

Fig. 15. Torque for cable glands

### 4.3.1. Cable glands Wiring Best Practice

Follow wirings as indicated

Number	Terminal
1	Analog Output
2	Modbus RS-485
3	Power Supply
4	Relay Warning/Fault
5	Relay Alarm

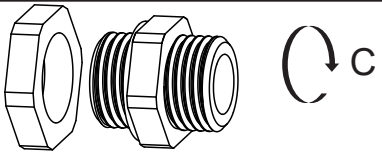
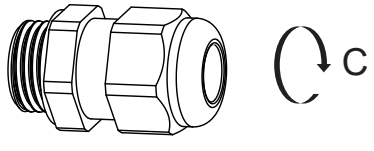
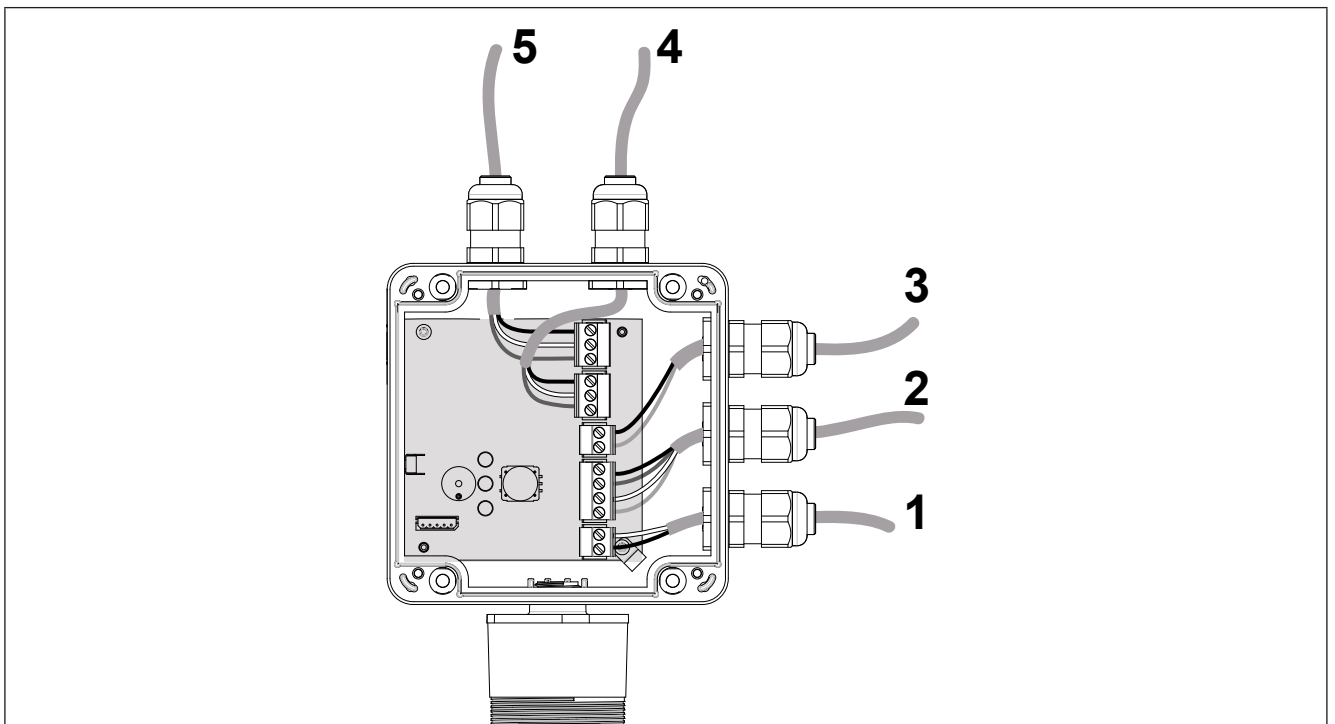

Fig. 16. Cable glands Wiring Best Practice LKDNext

- Use the cable glands provided to pass through and connect the cables to the terminals, as shown in the figure and in the connection table below. The terminals can be removed to simplify wiring.
- Cord range for M16 cable gland 6.0 - 8.6 mm, for M20 cable gland 7.5 - 11.3 mm
- Use UL listed approved cable, min. 50 °C, suitable for electrical rating in application
- Tighten the cable glands with a torque of 2,5 Nm
- Close the cover.
- Secure the detector cover with the four black lid screws provided using recommended torque 2.5 Nm.
- Power the device on and set the parameters using the "Eliwell Air App" app (see the relevant chapter) if the settings were not previously made using the service wheel.

LKDNext is provided with glands loose. IP degree depends on proper installation.

## ⚠ WARNING

### IP DEGREE LOST

- Install and operate this equipment according to the conditions described in the Environmental and electrical characteristics.
- Verify presence and correct position of cable glands gasket and relevant caps.
- Only use screws provided with the package to close the lid.
- Tighten screws in conformance with the torque specifications.

**Failure to follow these instructions can result in death, serious injury, or equipment damage.**

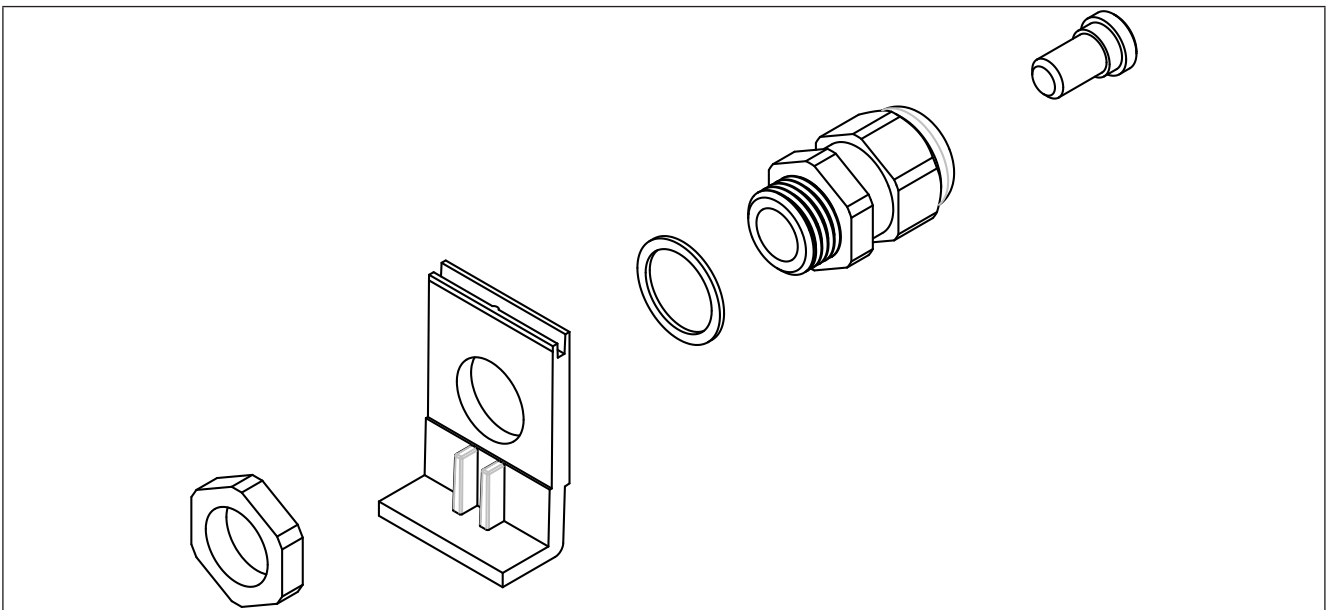

**Fig. 17. Cable glands LKDNext**



## 4.4. Refrigerant list

Group	Refrigerants		Tecnology
1	R32 mixtures	Type 1	Semiconductor (SC)
2	HFC/HFO	Type 2	Semiconductor (SC)
3	HC	Type 3	Semiconductor (SC)
4	CO2	-	Infrared (IR)
5	NH3	-	Elettrochemical (EC)

GTY	Gas	R-number	Sensor module group	Mixture [%]	Compounds [%/%]	Measuring range
1	-	R-22	2	N	-	0-1,000 ppm
2	-	R-134a	2	N	-	0-1,000 ppm
3	-	R-404A	2	125/143a/134a	44/52/4	0-1,000 ppm
4	-	R-407C	1	32/125/134a	23/25/52	0-1,000 ppm
5	-	R-410A	1	32/125	50/50	0-1,000 ppm
6	NA	-	-	-	-	-
7	Propane (C3H8)	R-290	3	N	-	0-4,000 ppm
8	NA	-	-	-	-	-
9	Butane	R-600A	3	N	-	0-4,000 ppm (1)
10	Ammonia (NH3)	R-717	5	N	-	0-5,000 ppm
11	CO2	R-744	4	N	-	0-10,000 ppm
12	NA	-	-	-	-	-
13	Propylene	R-1270	3	N	-	0-4,000 ppm (3)
14-18	NA	-	-	-	-	-
19	-	R-407A	1	32/125/134a	20/40/40	0-1,000 ppm
20-21	NA	-	-	-	-	-
22	-	R-407F	1	32/125/134a	30/30/40	0-1,000 ppm
23	-	R-32	1	N	-	0-1,000 ppm
24-26	NA	-	-	-	-	-
27	-	R-1234yf	2	N	-	0-1,000 ppm
28	-	R-1234ze	2	N	-	0-1,000 ppm
29	Solstice L40X	R-455A	1	744/32/1234yf	3/21,5/75,5	0-1,000 ppm
30-32	NA	-	-	-	-	-
33	-	R-448A	1	32/125/1234yf/134a/1234ze	26/26/20/21/7	0-1,000 ppm
34	-	R-449A	1	32/125/1234yf/134a	24,3/24,7/25,3/25,7	0-1,000 ppm
35	-	R-450A	2	134a/1234ze(E)	42/58	0-1,000 ppm
36	-	R-452A	1	32/125/1234yf	11/59/30	0-1,000 ppm
37	NA	-	-	-	-	-
38	Solstice L41Y	R-452B	1	32/125/1234yf	TBD	0-1000 ppm

GTY	Gas	R-number	Sensor module group	Mixture [%]	Compounds [%/0%]	Measuring range
39	-	R-513A	2	134a/1234yf	44/56	0-1000 ppm
40	-	R-454B	1	32/1234yf	68,9/31,1	0-1000 ppm
41-42	NA	-	-	-	-	-
43	OPTEON XL40	R-454A	1	32/1234yf	35/65	0-1000 ppm
44	OPTEON XL20	R-454C	1	32/1234yf	21,5/78,5	0-1000 ppm
45-46	NA	-	-	-	-	-
47	-	R-466A	1	CF3I/32/125	39,5/49/11,5	0-1000 ppm
48	-	R-464A	1	32/125/1234zeE/227ea	27,0/27,0/40,0/6,0	0-1000 ppm
49	-	R-465A	1	32/290/1234yf	21,0/7,9/71,1	0-1000 ppm
50	-	R-468A	1	1132a/32/1234yf	3,5/21,5/75,0	0-1000 ppm
51	-	R-1233zde	2	N	-	0-1000 ppm
52	CH4	R-50	3	N	-	0-4000 ppm
53	Ethylene	R-1150	3	N	-	0-4000 ppm (2)
54	-	R-507A	1	1132a/32/1234yf	3,5/21,5/75,0	0-1000 ppm

- (1) (Hydrocarbon) Butane: 100% LFL = 13,000 ppm  
(2) (Hydrocarbon) Ethylene: 100% LFL = 23,000 ppm  
(3) (Hydrocarbon) Propylene: 100% LFL = 20,000 ppm  
Methane: 100% LFL = 44,000 ppm

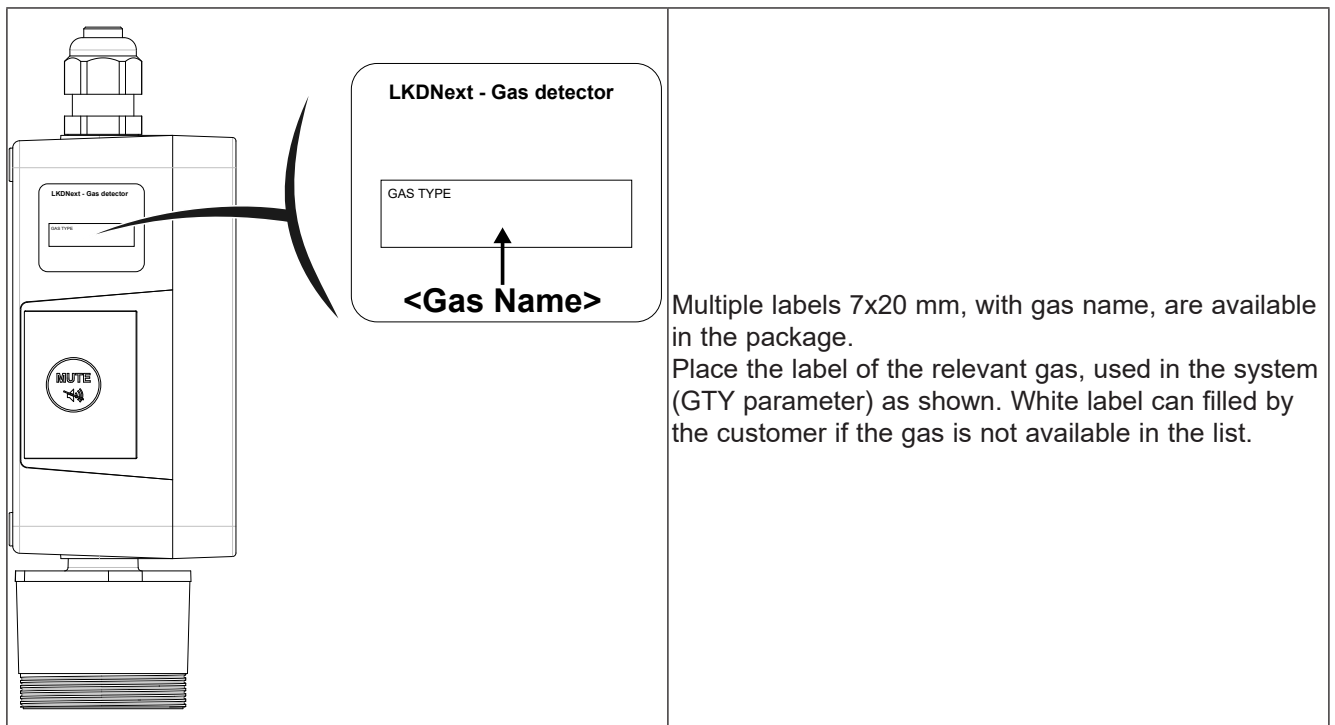

**Fig. 18. Gas Type Label**

---

## CHAPTER 5

### Operation

---

#### 5.1. Device operating states

When power is connected, the device begins the start-up cycle, divided into two phases:

- start-up
- warm-up

The start-up sequence lasts around 20 seconds, during which the main functions of the gas detector are initialised and verified. In this phase, the LEDs on the front panel are activated in sequence, and the device cannot yet be used.

At the end of the start-up sequence, the warm-up phase commences, during which the sensor output signal is adjusted and stabilised. In this phase, the device can be used to detect gas and installation can be completed via the service wheel, app or supervisor; nonetheless, the measurement is less reliable and calibration is not possible.

<b><i>NOTICE</i></b>
----------------------

<b>INOPERABLE EQUIPMENT</b>
-----------------------------

During start-up sequence the device cannot yet be used.

**Failure to follow these instructions can result in equipment damage.**

During the warm-up phase, the green LED flashes around twice every second. The duration of the warm-up phase depends on the sensor technology used:

- Semiconductor = 5 minutes
- Electrochemical = 5 minutes
- Infrared = 2 minutes

The duration of the warm-up phase may also vary according to environmental conditions. In this phase it is important not to cause sudden changes in gas concentration, so as to avoid compromising correct measurement by the sensor.

The sensors may take longer to warm up than specified; in these cases, do not take any action, wait for the device to stabilise. The time needed for complete stabilisation of the device may vary from 2 hours (minimum time) to 24 hours (recommended time).

<b><i>NOTICE</i></b>
----------------------

<b>INOPERABLE EQUIPMENT</b>
-----------------------------

Let the device complete stabilisation before use.

**Failure to follow these instructions can result in equipment damage.**

## 5.2. LEDs

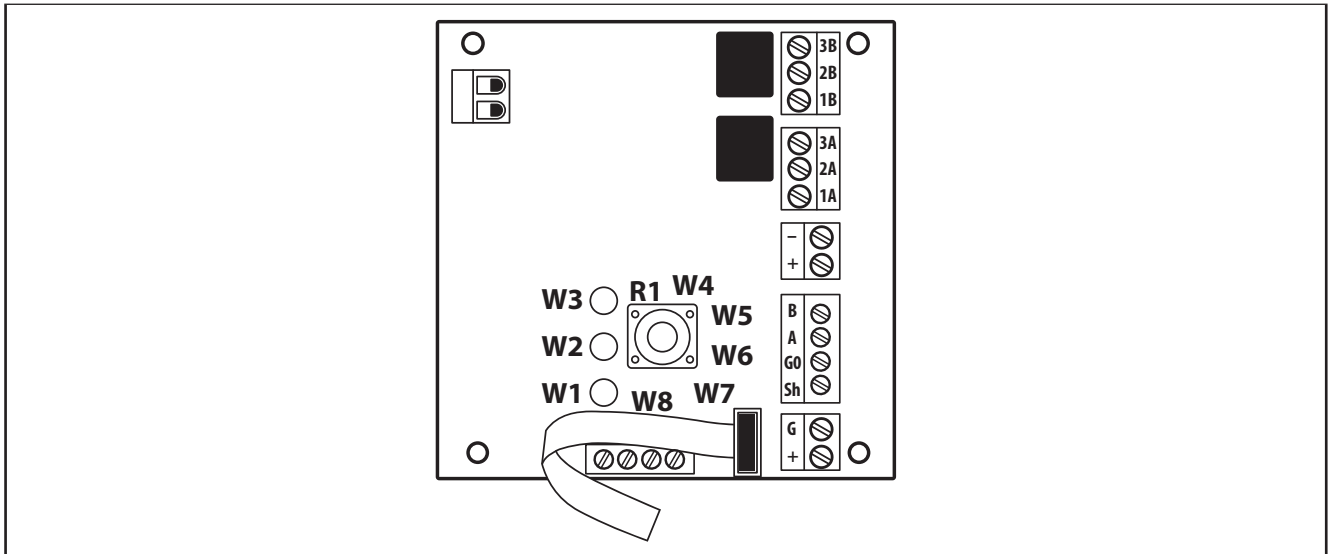

Fig. 19. LEDs

<b>R1</b>	Wheel	Service Wheel
<b>W1</b>	Not used	Not used for service wheel set-up
<b>W2</b>	Warning level	Warning threshold
<b>W3</b>	Alarm level	Alarm threshold
<b>W4</b>	Alarm Modbus Address	Modbus Address selection
<b>W5</b>	Alarm delay	Delay time for activating the LED and alarm relay after exceeding the alarm threshold
<b>W6</b>	Analog output	Type of analog output
<b>W7</b>	Alarm/Warning reset function mode	Alarm/Warning reset function mode
<b>W8</b>	Modbus configuration	Modbus configuration

## 5.4. Device operating states

The LKDNext series gas detectors provide visual indications of their current operating status, in addition to the relay outputs. Visual indication of device operating status is provided by three LEDs (yellow/green/red/). Device status and the corresponding outputs are shown in the following table:

Status		LED			Warning/Fault relay <sup>(1)</sup>	Alarm relay <sup>(1)</sup>	Buzzer
Warm-up		-		-	OFF	OFF	Deactivated
Normal		-		-	OFF	OFF	Deactivated
APP connected to LKDNext <sup>(2)</sup>		-		-	OFF	OFF	Deactivated
Ongoing Modbus communication for 2 seconds		Internal LED W8 constantly lit			-	-	-
Warning, Delayed					OFF	OFF	Deactivated
Alarm, Delayed	(DFR <sup>(3)</sup> = 0)				ON	OFF	Deactivated
	(DFR <sup>(3)</sup> = 1)				OFF	OFF	Deactivated
Warning	(DFR <sup>(3)</sup> = 0)				ON	OFF	Deactivated
	(DFR <sup>(3)</sup> = 1)				OFF	OFF	Deactivated
Alarm	(DFR <sup>(3)</sup> = 0)				ON	ON	Activate
	(DFR <sup>(3)</sup> = 1)				OFF	ON	Activate
Fault	(DFR <sup>(3)</sup> = 0)		-		ON	ON	Activate
	(DFR <sup>(3)</sup> = 1)		-		ON	OFF	Activate

<sup>(1)</sup> ON and OFF meaning based on Failsafe function status. See table below  
<sup>(2)</sup> Eliwell AIR App connected  
<sup>(3)</sup> DFR: Dedicat Fault Relay enable

## Advanced buzzer mode

(firmware version greater than or equal to 2.14, produced after October 2025)

The Advanced buzzer mode, enabled by default with the parameter “ABZR (Advanced buzzer)” set to 1, set buzzer notifications for both Warning and Alarm state. By setting ABZR to 0 it is possible to have buzzer notification just for Alarms.

Status	BUZZER SOUND	
LKD state	ABZR=0 (Standard buzzer)	ABZR=1 (Advanced buzzer)
Warning	OFF	3 seconds ON / 3 seconds OFF
Alarm	ON	1 seconds ON / 1 seconds OFF
Fault	ON	ON

## Relay ON and OFF meaning

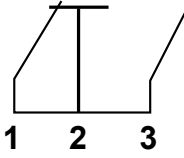
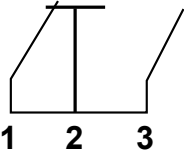
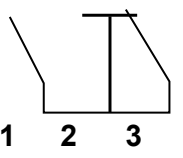
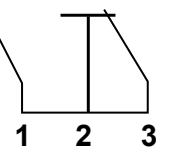
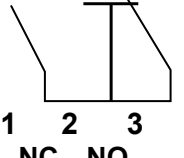
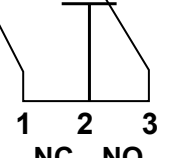
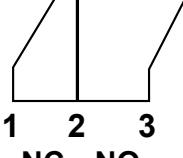
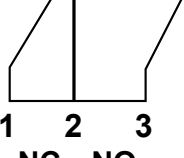
Fail-safe	Relay ON	Relay OFF		
Active FSR = 0 (Default)	 1 2 3 NC NO Warning relay	 1 2 3 NC NO Alarm relay	 1 2 3 NC NO Warning relay	 1 2 3 NC NO Alarm relay
Deactive FSR = 1	 1 2 3 NC NO Warning relay	 1 2 3 NC NO Alarm relay	 1 2 3 NC NO Warning relay	 1 2 3 NC NO Alarm relay

## 'Relay as a Buzzer' function

(firmware version greater than or equal to 2.14, produced after October 2025)

This function is used to define when a relay is used to control an external buzzer. If set so, the Mute button affect its behaviour in the same way it affects the internal buzzer.

**NOTE:** When setting this function, be careful and double-check when setting the 'relay as a buzzer.' Help ensure that you carefully inspect what is connected to that relay to avoid undesired behavior. For instance, if a system or a device is connected to a relay set as a buzzer, it could be deactivated by pressing the Mute button.

The function is set by two independent parameters:

1. Is the warning relay a buzzer? (WRB, default = 0)
2. Is the alarm relay a buzzer? (ARB, default = 0)

If any of these parameters is activated, the respective relay will follow the behavior of the internal buzzer.

Fault condition has the highest priority and will activate the dedicated Fault relay (or relays) with no regard to WRB and ARB parameter settings.

The functionality of the MUTE/RESET button is the same as for the on-board buzzer.

	Manual / Automatic mode	
	WRB / ARB = 0	WRB / ARB = 1
Warning relay	As is. Not affected by MUTE button	Mimics the buzzer
Alarm relay	As is. Not affected by MUTE button	Mimics the buzzer

## 5.6. Service Wheel

The service wheel (R1) is located inside the device, on the electronic board.

**NOTE.** The multimeter is not included in the offer

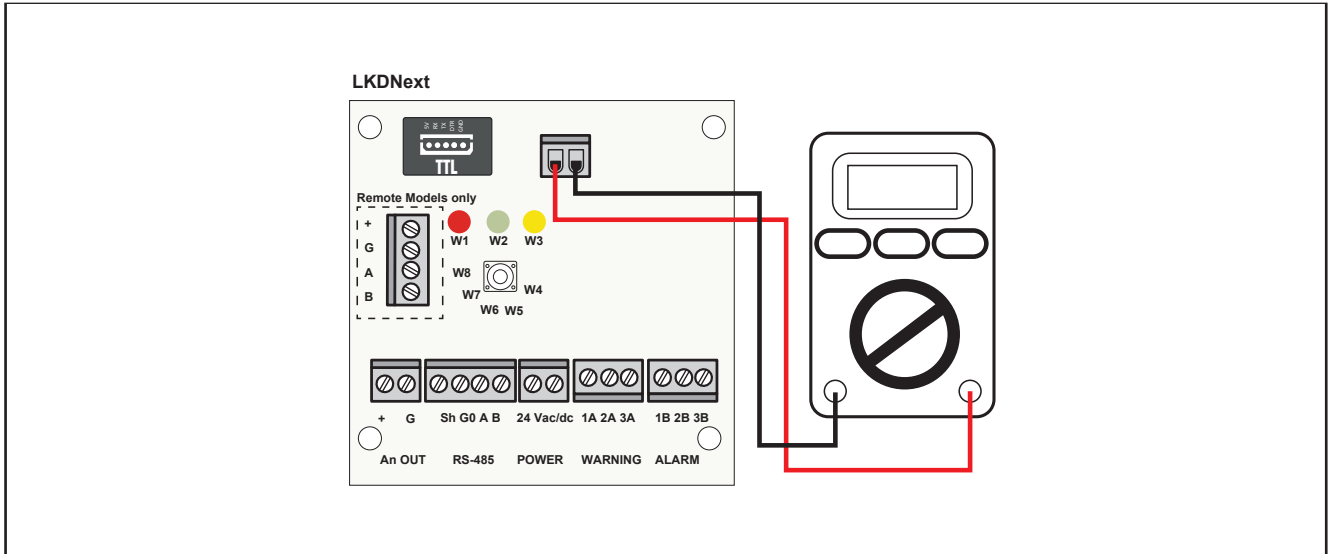

**Fig. 20.** Service Wheel

The basic configuration can be performed using the service wheel, following the instructions described below. To complete the configuration, a digital multimeter is required, with the test leads connected to connector J6. In this way, the tester will show a voltage between 0 and 10 Volts, indicating the value selected by the service wheel. The meaning of the voltage value displayed changes depending on the selected function: the table below shows the meaning of each voltage for each function.

1. Setting mode is activated by pressing and holding the service wheel for 5 seconds. The LED that is ON acts as the menu point, indicating which parameters will be set (all the other LEDs are OFF). Turn the switch to select the parameter to be set. Reading the table, the voltage read with a voltmeter connected to the service terminal indicates the chosen setting.
2. Pressing the service wheel for 2 seconds accesses the selected parameter. The corresponding LED flashes.
3. Turning the service wheel changes the parameter setting.
4. After having made the setting, pressing the service wheel for 5 seconds saves the new value. Marked by steady led light. Cancel by continue holding for an additional 5 seconds (total 10 seconds). Marked by flashing light.
5. Turning the service wheel again moves to the next parameter.
6. After two minutes of inactivity or pressing the service wheel for 10 seconds, the detector returns to normal operating mode.

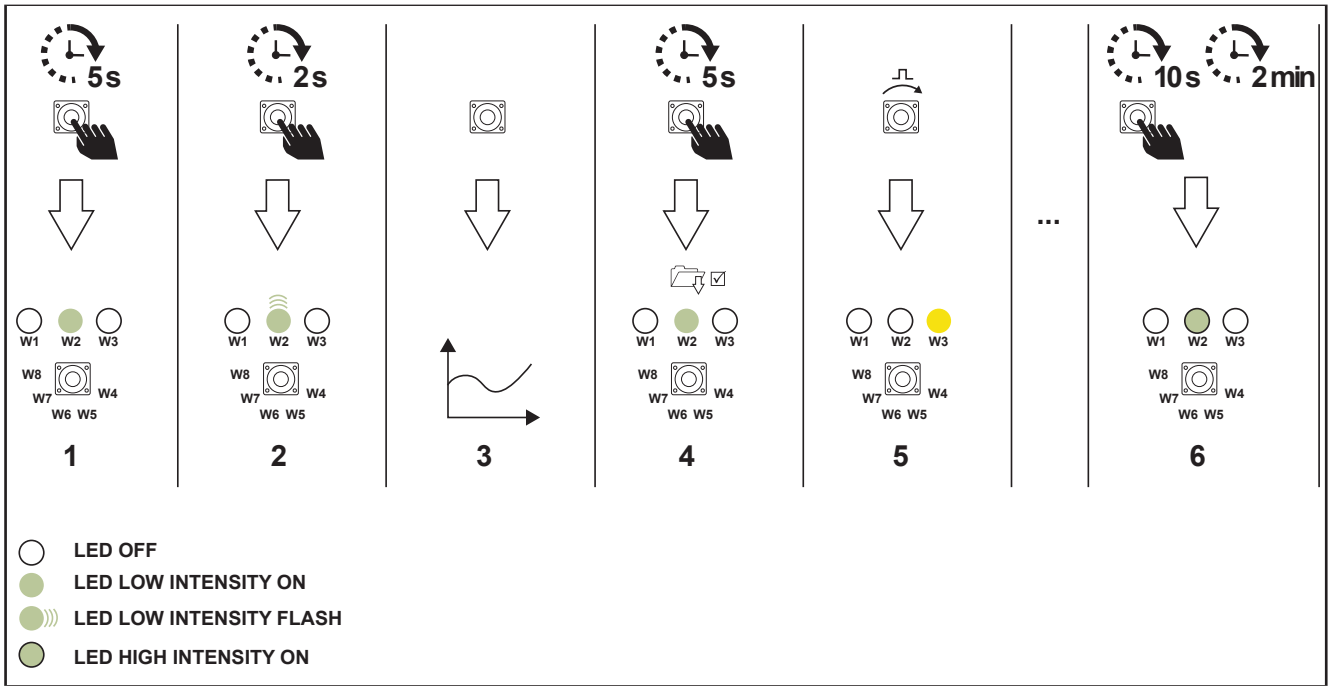

Fig. 21. Service Wheel procedure



### 5.6.1. Description of the service wheel LEDs

The table below shows the value of the selected parameter and the corresponding voltage value. Each LED corresponds to a different parameter. The default parameter values are saved to permanent memory.

LED	Meaning	Description
W1	Not used	Not used for service wheel set-up.
W2	Warning level	The operator can set the warning threshold. See the table below for the voltage value corresponding to the selected setting.
W3	Alarm level	The operator can set the alarm threshold. See the table below for the voltage value corresponding to the selected setting.
W4	Modbus address	The operator can set the Modbus address.
W5	Alarm delay	The operator can select the delay time for activation of the LED and the alarm relay after the alarm threshold has been exceeded. See the table below for the voltage value corresponding to the selected setting.
W6	Type of analog output voltage	The operator can select the type of analog output. See the table below for the voltage value corresponding to the selected setting.
W7	LED W7 Alarm/warning reset function mode	This parameter is used to select the warning and alarm reset modes. 0 = manual reset (latch) / 1 = automatic reset <b>See "Analog output" on page 37</b>
W8	Modbus configuration	The operator can choose the desired Modbus configuration from the options available. See the table below for the voltage value corresponding to the selected setting.

### 5.6.2. Possible configurations - Alarm/warning reset function mode (W7)

Alarm/warning reset function mode (W7)		Warning	Alarm
W=0	A = 0	Manual Reset	Manual Reset
W=1	A = 0	Automatic Reset	Manual Reset
W=0	A = 1	Manual Reset	Automatic Reset
W=1	A = 1	Automatic Reset	Automatic Reset
* W: Warning, A: Alarm			
0 = Manual (latch) reset / 1 = automatic reset			

### 5.6.3. Service voltage value conversion table / selected function

	Service wheel LED							
	W2 / W3 Warning level / Alarm level			W4 Modbus Address	W5 Alarm / Warning Delay	W6 Analog Output	W7 Alarm/ Warning reset function mode	W8 Modbus configuration
	Full scale 100	Full scale 4000	Full scale 10000					
Voltage [V]	[ppm]	[ppm]	[ppm]	-	-	-	-	-
0	0	0	0	0	0	-	-	-
0,1	1	100	100	1	1	-	-	-
0,2	2	200	200	2	2	-	-	-
0,3	3	300	300	3	3	-	-	-
0,4	4	400	400	4	4	-	-	-
0,5	5	500	500	5	5	-	-	-
0,6	6	600	600	6	6	-	-	-
0,7	7	700	700	7	7	-	-	-
0,8	8	800	800	8	8	-	-	-
0,9	9	900	900	9	9	-	-	-
1	10	1000	1000	10	10	-	-	9600 8N1
1,1	11	1100	1100	11	11	-	-	-
1,2	12	1200	1200	12	12	-	-	-
1,3	13	1300	1300	13	13	-	-	-
1,4	14	1400	1400	14	14	-	-	-
1,5	15	1500	1500	15	15	-	-	-
1,6	16	1600	1600	16	16	-	-	-
1,7	17	1700	1700	17	17	-	-	-
1,8	18	1800	1800	18	18	-	-	-
1,9	19	1900	1900	19	19	-	-	-
2	20	2000	2000	20	20	4-20 mA	W=0 A=0	9600 8N2
2,1	21	2100	2100	21	-	-	-	-
2,2	22	2200	2200	22	-	-	-	-
2,3	23	2300	2300	23	-	-	-	-
2,4	24	2400	2400	24	-	-	-	-
2,5	25	2500	2500	25	-	-	-	-
2,6	26	2600	2600	26	-	-	-	-
2,7	27	2700	2700	27	-	-	-	-
2,8	28	2800	2800	28	-	-	-	-
2,9	29	2900	2900	29	-	-	-	-
3	30	3000	3000	30	-	-	-	19200 8N1
3,1	31	3100	3100	31	-	-	-	-
3,2	32	3200	3200	32	-	-	-	-
3,3	33	3300	3300	33	-	-	-	-
3,4	34	3400	3400	34	-	-	-	-
3,5	35	3500	3500	35	-	-	-	-
3,6	36	3600	3600	36	-	-	-	-
3,7	37	3700	3700	37	-	-	-	-
3,8	38	3800	3800	38	-	-	-	-

	Service wheel LED							
	W2 / W3 Warning level / Alarm level			W4 Modbus Address	W5 Alarm / Warning Delay	W6 Analog Output	W7 Alarm/ Warning reset function mode	W8 Modbus configuration
	Full scale 100	Full scale 4000	Full scale 10000					
Voltage [V]	[ppm]	[ppm]	[ppm]	-	-	-	-	-
3,9	39	3900	3900	39	-	-	-	-
4	40	4000	4000	40	-	-	-	19200 8N2
4,1	41	-	4100	41	-	-	-	-
4,2	42	-	4200	42	-	-	-	-
4,3	43	-	4300	43	-	-	-	-
4,4	44	-	4400	44	-	-	-	-
4,5	45	-	4500	45	-	-	-	-
4,6	46	-	4600	46	-	-	-	-
4,7	47	-	4700	47	-	-	-	-
4,8	48	-	4800	48	-	-	-	-
4,9	49	-	4900	49	-	-	-	-
5	50	-	5000	50	-	1-5 V	W=1 A=0	-
5,1	51	-	5100	51	-	-	-	-
5,2	52	-	5200	52	-	-	-	-
5,3	53	-	5300	53	-	-	-	-
5,4	54	-	5400	54	-	-	-	-
5,5	55	-	5500	55	-	-	-	-
5,6	56	-	5600	56	-	-	-	-
5,7	57	-	5700	57	-	-	-	-
5,8	58	-	5800	58	-	-	-	-
5,9	59	-	5900	59	-	-	-	-
6	60	-	6000	60	-	-	-	9600 8E1
6,1	61	-	6100	61	-	-	-	-
6,2	62	-	6200	62	-	-	-	-
6,3	63	-	6300	63	-	-	-	-
6,4	64	-	6400	64	-	-	-	-
6,5	65	-	6500	65	-	-	-	-
6,6	66	-	6600	66	-	-	-	-
6,7	67	-	6700	67	-	-	-	-
6,8	68	-	6800	68	-	-	-	-
6,9	69	-	6900	69	-	-	-	-
7	70	-	7000	70	-	-	-	19200 8E1
7,1	71	-	7100	71	-	-	-	-
7,2	72	-	7200	72	-	-	-	-
7,3	73	-	7300	73	-	-	-	-
7,4	74	-	7400	74	-	-	-	-
7,5	75	-	7500	75	-	-	-	-
7,6	76	-	7600	76	-	-	-	-
7,7	77	-	7700	77	-	-	-	-
7,8	78	-	7800	78	-	-	-	-
7,9	79	-	7900	79	-	-	-	-
8	80	-	8000	80	-	2-10 V	W=0 A=1	9600 8O1
8,1	81	-	8100	81	-	-	-	-

	Service wheel LED							
	W2 / W3 Warning level / Alarm level			W4 Modbus Address	W5 Alarm / Warning Delay	W6 Analog Output	W7 Alarm/ Warning reset function mode	W8 Modbus configuration
	Full scale 100	Full scale 4000	Full scale 10000					
Voltage [V]	[ppm]	[ppm]	[ppm]	-	-	-	-	-
8,2	82	-	8200	82	-	-	-	-
8,3	83	-	8300	83	-	-	-	-
8,4	84	-	8400	84	-	-	-	-
8,5	85	-	8500	85	-	-	-	-
8,6	86	-	8600	86	-	-	-	-
8,7	87	-	8700	87	-	-	-	-
8,8	88	-	8800	88	-	-	-	-
8,9	89	-	8900	89	-	-	-	-
9	90	-	9000	90	-	-	-	19200 8O1
9,1	91	-	9100	91	-	-	-	
9,2	92	-	9200	92	-	-	-	-
9,3	93	-	9300	93	-	-	-	-
9,4	94	-	9400	94	-	-	-	-
9,5	95	-	9500	95	-	-	-	-
9,6	96	-	9600	96	-	-	-	-
9,7	97	-	9700	97	-	-	-	-
9,8	98	-	9800	98	-	-	-	-
9,9	99	-	9900	99	-	-	-	-
10	100	-	10000	100	-	0-10 V	W=1 A=1	-

---

## 5.7. Setting parameters via Modbus

### Introduction

Modbus is a client/server protocol for communication between devices connected in a network. Modbus devices communicate using a master-slave technique in which only one device (master) can send messages. The other devices in the network (slave) respond, returning the data requested by the master or executing the action contained in the message sent. A slave is a device connected to a network that processes information and sends the results to the master using the Modbus protocol.

The master device can send messages to individual slaves, or to the entire network (broadcast), whilst slave devices can only respond to messages individually and to the master device. The Modbus standard used by Eliwell employs the RTU code for data transmission.

### Data format (RTU)

The coding type used defines the structure of messages transmitted on the network and the way in which this information is deciphered. The coding type is usually chosen according to specific parameters (baudrate, parity, stop), plus certain devices only support specific coding types. Use the same coding type for all devices connected to a Modbus network.

The protocol uses the RTU binary method with the serial frame configured as follows:

Parameter	Possible values	Default value
Address	0 to 247 via app 0 to 100 via device	1
Baud rate	9600 or 19200 bps	19200 bps
Stop bit	1 or 2	1
Parity	None Odd Even	Even

### Modbus commands available and data areas

Modbus command	Description
03 (hex 0x03)	Read resources
16 (hex 0x10)	Write resources
43 (hex 0x2B)	Read device ID. The following 3 fields can be read: <ul style="list-style-type: none"><li>• <b>0 = Manufacturer ID</b></li><li>• <b>1 = Model ID</b></li><li>• <b>2 = Family ID (MSK 4003) / device version</b></li></ul>

Note: Maximum length of transmitted/received messages equal to 2 bytes, 1 modbus word.

---

## 5.8. Modbus network

For the Modbus RS485 network, use a shielded 3-wire cable. Recommended: Belden 3106A (or equivalent). The Modbus communication parameters can only be set using the Eliwell Air App app or the service wheel on the device's electronic board.

Make sure that the network communication parameters are configured in the same way, including on the controller. To help ensure optimal operation of the serial network, observe the following guidelines:

- make sure that the devices are configured with a single bus layout. Connecting several buses in parallel or branching several devices from the main bus may introduce incorrect combinations of signal impedance, reflections and/or distortions.
- Avoid using excessively long connections when connecting devices to the serial bus. The device - bus connection must not exceed a maximum length of 100 metre.
- Make sure that the polarity of the A / B signal is maintained across the serial network.
- Earth the cable shield only on the main unit side.
- Connect the cable shield to terminal SH on the gas detector.
- Make sure that the shield is intact across the serial network.
- Do not use the shield connection as a signal reference. Use a cable that provides a dedicated wire for the signal reference.
- Connect the signal reference to terminal GND on the gas detector.

The LKDNext series gas detectors feature a Modbus RTU digital interface. All of the status messages and most of the parameters accessible and/or configurable via the Bluetooth® interface are also accessible and/or configurable via MODBUS controller.

## Parameters for RS485 communication selectable via app or service wheel

### Description of the columns

**LABEL**

Indicates the name with which the parameter appears in the menu.

**DESCRIPTION**

Description of the parameter's meaning.

**ADDR**

Represents the Modbus register address which contains the read or write value of the resource in the device.

**FILTER**

Represents the position of the most significant data bit inside the register. This information is always provided when the register contains more than one piece of information and it is necessary to distinguish which bits actually represent the data (the useful size of the data, indicated in the DATA SIZE column, should also be taken into account).

**R/W**

Indicates the option of reading or writing the resource:

- R = the resource is read-only
- W = the resource is write-only
- RW = the resource can be both read and written

**DATA SIZE**

Indicates the size of the piece of data (in bit):

- WORD = 16 bit
- Byte = 8 bit
- "n" bit = 0...15 bit based on the value of "n"

**CPL**

Always N. The value read by the register no needs to be converted. The value is always positive or null.

**RANGE**

Describes the interval of values that can be assigned to the parameter. This range can be correlated to the value of other parameters.

**MU**

Unit of measure for the values.

**DEF**

Parameter default.

## 5.8.1. Parameters Address

LABEL	R/W	CPL	RANGE	ADDR	DATA SIZE	DESCRIPTION	UM	DEF
FWVer	R	N	-	107	16	Firmware version	num	-
HWVer	R	N	-	113	16	Hardware version	num	-
dUS	R	N	0 ... 999	115	16	Gas concentration unit 0 = ppm; 1 = %VOL; 2 = %LEL 3...999 = RESERVED	num	0
GasGr	R	N	1 ... 5	117	16	Gas group 1 = R32 mixtures, 2 = HFC/HFO, 3 = HC, 4 = CO <sub>2</sub> , 5 = NH <sub>3</sub>	num	(1)
DSS	R	N	0 ... 65535	118	16	Days since last service	Day	-
LTS	R	N	0 ... 65535	119	16	Max allowed online days for sensor before change is needed	Day	-
MDS	R	N	0 ... 65535	120	16	Max days until next service	Day	-
HAL	RW	N	WAL ... FUL (2)	200	16	Maximum alarm threshold	(3) see dUS	(1)
WAL	RW	N	0 ... HAL	203	16	Threshold for warning	(3) see dUS	(1)
AOd	RW	N	0 ... 20	201	16	Alarm / Warning delay	min	0
AOt	RW	N	2/5/8/10	204	16	Analog output 1 type Type of analog output signal 2 = 4...20 mA 5 = 1...5 V 8 = 2...10 V 10 = 0...10 V	num	2
GTY	RW	N	1 ... 54	206	16	Select refrigerant type (1) See "4.4. Refrigerant list" on page 41	num	(1)
BMD	RW	N	1 ... 60	207	16	Buzzer Reactivation Time Interval	min	5
LEDW	R	N	0 ... 1	305	16	LED Warning (Yellow)	num	0
LEDN	R	N	0 ... 1	304	16	LED Normal (Green)	num	0
LEDE	R	N	0 ... 1	303	16	LED Alarm (Red)	num	0
CEF	R	N	0 ... 1	311	16	Sensor calibration expired	num	0
FSR	RW	N	0 ... 1	403	16	Failsafe relay enable 0 = Relay in failsafe mode 1 = Relay not in failsafe mode	num	0
DFR	RW	N	0 ... 1	404	16	Dedicated fault relay enable 0 = Warning relay not used as fault 1 = Warning relay used as fault	num	0
WRR	RW	N	0 ... 1	405	16	Warning reset mode selection (automatic/manual) 0 = manual reset 1 = automatic reset	num	0

LABEL	R/W	CPL	RANGE	ADDR	DATA SIZE	DESCRIPTION	UM	DEF
ALb	RW	N	0 ... 1	406	16	Alarm reset mode selection (automatic/manual) 0 = manual reset 1 = automatic reset	num	0
Adr	RW	N	1 ... 247	600	16	Modbus protocol controller address	num	1
bAU	RW	N	9600/19200	601	16	Baudrate selection 9600 = 9600 bps 19200 = 19200 bps	num	19200
PtY	RW	N	69 /78/79	602	16	Modbus parity bit 69 = even parity 78 = No parity 79 = odd parity	num	69
StP	RW	N	1 ... 2	603	16	Modbus stop bit 1 = 1 bit 2 = 2 bits	num	1
AO_Val <sup>(4)</sup>	RW	N	0 ... 100	605	16	Set value of analog output	%	0
tEm	R	Y	-32767,0 .. 32768,0	503	16	Sensor Module Temperature	°C	0

<sup>(1)</sup> depending on Sensor type;

<sup>(2)</sup> FUL: full range of sensor;

<sup>(3)</sup> UM based on parameter dUS

<sup>(4)</sup> Active Commands in Test Mode only (via APP or Modbus)

## 5.8.2. Resources Address

LABEL	R/W	CPL	RANGE	ADDR	FILTER	DATA SIZE	DESCRIPTION	UM
GCon	R	N	0 ... 65535	101	-	16	Gas concentration in display unit	num
DayN	R	N	0 ... 65535	105	-	16	Sensor timer	Day
AO	R	N	0.0 ... 100.0	116	-	16	Analogue output 1	%
FAU	R	N	0 ... 1	302	-	16	Sensor fault alarm 0= sensor fault alarm not active 1= sensor fault alarm active	num
ErCOM	R	N	0 ... 1	102	1	16	No communication from sensor module	num
ErCOMCh	R	N	0 ... 1	102	2	16	No communication from sensor chip	num
SSt	R	N	0 ... 1	102	4	16	Sensor startup on-going	num
SOVR	R	N	0 ... 1	102	16	16	Sensor Over range	num
SUNR	R	N	0 ... 1	102	32	16	Sensor Under range	num



LABEL	R/W	CPL	RANGE	ADDR	FILTER	DATA SIZE	DESCRIPTION	UM
PWR	R	N	0 ... 1	307	-	16	Pre Warning 0 = Pre Warning OFF 1 = Pre Warning ON	num
WR	R	N	0 ... 1	308	-	16	Warning activation indicator including delay 0 = Warning OFF 1 = Warning ON	num
PALR	R	N	0 ... 1	300	-	16	Pre Alarm 0 = Pre Alarm OFF 1 = Pre Alarm ON	num
ALR	R	N	0 ... 1	309	-	16	Alarm activation indicator including delay 0 = Alarm OFF 1 = Alarm ON	num
BTS	R	N	0 ... 1	310	-	16	Bluetooth connection status 0 = Eliwell AIR App not connected 1 = Eliwell AIR App connected	num
SER	R	N	0 ... 1	401	-	16	Service requested 0= Not Requested 1= Requested	num
SER_OK	RW	N	0 ... 1	401	-	16	Reset service request (Including calibration) write 0 to reset after service	num
AcA	W	N	0 .. 1	402	-	16	Alarm silencing	flag
FRES <sup>(1)</sup>	W	N	0 ... 1	409	-	16	Restore factory setting 0 = none 1 = restore detector to factory	flag
RL1_ON <sup>(1)</sup>	W	N	0 ... 1	800	-	16	Relay Output 1 ON	flag
RL1_OFF <sup>(1)</sup>	W	N	0 ... 1	800	-	16	Relay Output 1 OFF	flag
RL2_ON <sup>(1)</sup>	W	N	0 ... 1	801	-	16	Relay Output 2 ON	flag
RL2_OFF <sup>(1)</sup>	W	N	0 ... 1	801	-	16	Relay Output 2 OFF	flag
LEDG_ON <sup>(1)</sup>	W	N	0 ... 1	804	-	16	Green LED activation	flag
LEDG_OFF <sup>(1)</sup>	W	N	0 ... 1	804	-	16	Green LED deactivation	flag
LEDR_ON <sup>(1)</sup>	W	N	0 ... 1	803	-	16	Red LED activation	flag
LEDR_OFF <sup>(1)</sup>	W	N	0 ... 1	803	-	16	Red LED deactivation	flag
LEDY_ON <sup>(1)</sup>	W	N	0 ... 1	805	-	16	Yellow LED activation	flag
LEDY_OFF <sup>(1)</sup>	W	N	0 ... 1	805	-	16	Yellow LED deactivation	flag
TEST_ON	W	N	0 ... 1	820	-	16	Test Mode On	flag
TEST_OFF	W	N	0 ... 1	820	-	16	Test Mode Off	flag

LABEL	R/W	CPL	RANGE	ADDR	FILTER	DATA SIZE	DESCRIPTION	UM
BUZ_ON <sup>(1)</sup>	W	N	0 ... 1	410	-	16	Buzzer activation	flag
BUZ_OFF <sup>(1)</sup>	W	N	0 ... 1	410	-	16	Buzzer deactivation	flag
<sup>(1)</sup> Active Commands in Test Mode only (via APP or Modbus)								

## 5.9. Alarm / Warning management

The alarms are activated when the set thresholds are exceeded. The alarm threshold value must always be greater than the warning value. The alarm and warning thresholds must be less than or equal to the full-scale range and must be greater than or equal to the allowed limit. The alarms are activated when the set thresholds are exceeded.

### Alarm set points

Sensor, gas and range	Minimum value	Maximum value	Default		UM
			Alarm	Warning	
SC, R32 & mix 0-1000 ppm	150	800	500	150	ppm
SC, R290, 0-4000 ppm	400	3'000	800	400	
IR, CO2, 0-10000 ppm	1'500	8'000	5'000	1'500	
EC, NH3, 0-100 ppm	10	90	30	15	
EC, NH3, 0-1000 ppm	100	800	300	150	
EC, NH3, 0-5000 ppm	500	4500	1000	500	
SC, HFC/HFO 0-1000 ppm	150	900	900	700	

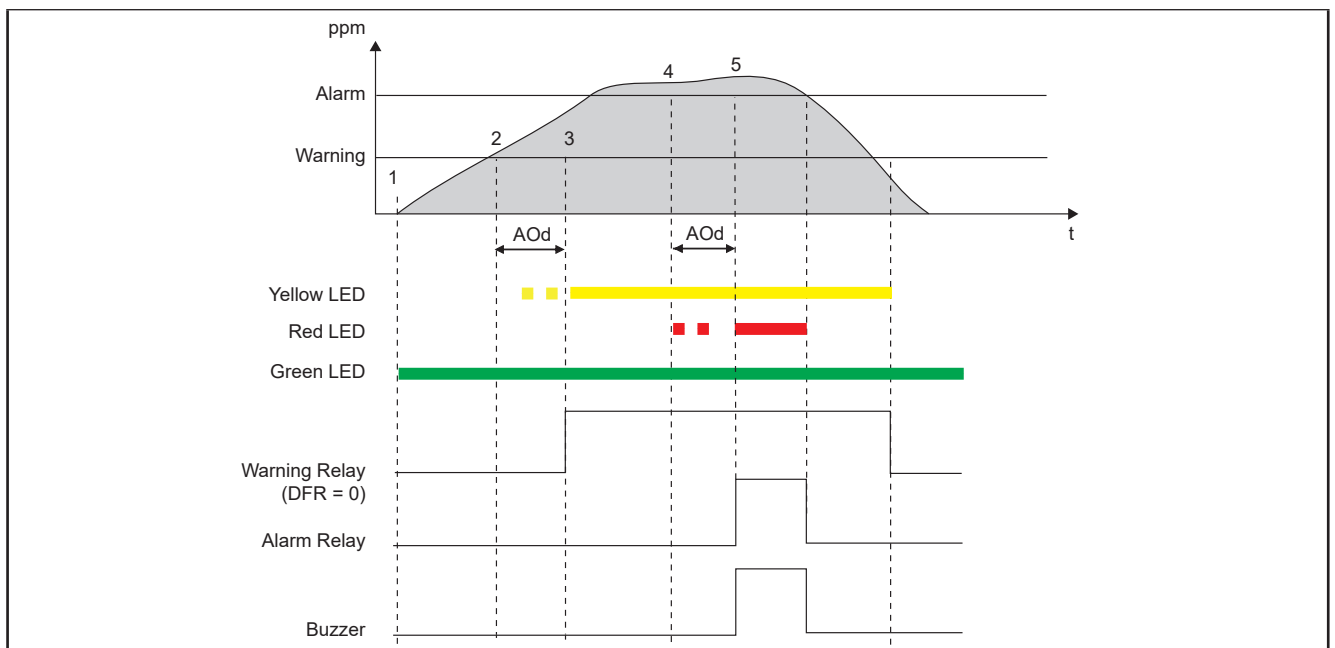

Fig. 22. Alarm/Warning sequences

1	2	3	4	5
300 PreAlarmflag = 0	300 PreAlarmflag = 0	300 PreAlarmflag = 0	300 PreAlarmflag = 1	300 PreAlarmflag = 1
307 PreWarningFlag = 0	307 PreWarningFlag = 1	307 PreWarningFlag = 1	307 PreWarningFlag = 1	307 PreWarningFlag = 1
308 WarningFlag = 0	308 WarningFlag = 0	308 WarningFlag = 1	308 WarningFlag = 1	308 WarningFlag = 1
309 AlarmFlag = 0	309 AlarmFlag = 0	309 AlarmFlag = 0	309 AlarmFlag = 0	309 AlarmFlag = 1
Yellow LED OFF	Yellow LED flashing	Yellow LED ON	Yellow LED ON	Yellow LED ON
Red LED OFF	Red LED OFF	Red LED OFF	Red LED flashing	Red LED ON
Warning relay OFF	Warning relay OFF	Warning relay ON	Warning relay ON	Warning relay ON
Alarm relay OFF	Alarm relay OFF	Alarm relay OFF	Alarm relay OFF	Alarm relay ON
Buzzer OFF	Buzzer OFF	Buzzer OFF	Buzzer OFF	Buzzer ON

### 5.9.1. Alarm/warning management

There are two types of alarm and warning management. Automatic reset mode (non-latched), manual reset mode (latched). To checking current mode use WRR parameter for Warning and ALb parameter for Alarm.

### Conditions when automatic reset option is chosen for Warning and Alarm

The relays and buzzer are triggered, when the gas concentration level exceeds the warning/alarm thresholds. The buzzer is muted for a pre-defined period of time (parameter BMD), when MUTE button is pressed during 2 seconds.

#### Mute button function

If LKDNext detects a gas concentration above warning or alarm thresholds for more than one second, the detector will enter alarm or warning mode (optionally waiting a buzzer muting duration set by parameter AOD "Alarm / Warning delay").

Acknowledge is only possible in latched alarm mode, while with Automatic mode it is only possible to mute the buzzer.

If the Warning or Alarm level will still be present after the mute duration, the buzzer is activated again.

	Automatic Mode	Manual (Latched) mode
Mute	Quick press and release of "MUTE" button	Quick press and release of "MUTE" button
Reset	Automatic reset of relays	4 seconds press "MUTE" button

The relays and buzzer are reset automatically, when the gas concentration level falls below the warning/alarm thresholds.

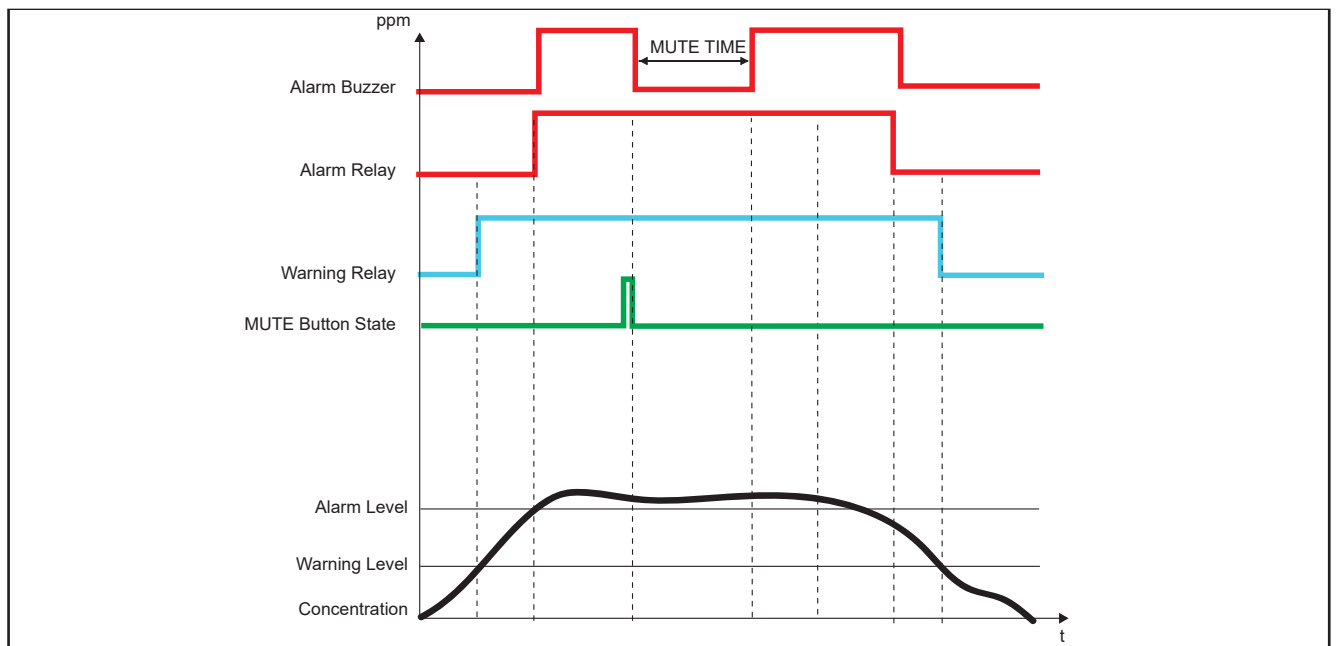

Fig. 23. Alarm/Warning sequences

---

## LED and buzzer function after automatic reset of Warning and Alarm

(firmware version greater than or equal to 2.14, produced after October 2025)

The Advanced automatic reset function introduces signals to identify such Alarm and Warning status which occurred but also automatically passed because the gas concentration decreased below the thresholds.

It applies only in automatic reset mode, since in manual mode the warning and alarms are disabled only by a direct interaction of the user.

By default, this mode is not active ("Advanced automatic reset" AAR = 0).

### Behaviour with no 'Advanced automatic reset' (AAR=0, default setting)

Automatic Mode (after Warning/Alarm have been automatically reset)				
	Green LED	Orange LED	Red LED	Buzzer
Warning	ON	OFF	OFF	OFF
Alarm	ON	OFF	OFF	OFF

### Behaviour with 'Advanced automatic reset' (AAR=1)

Automatic Mode (after Warning/Alarm have been automatically reset)							
	Green LED	Orange LED		Red LED		Buzzer	
	-	AAR=0	AAR=1	AAR=0	AAR=1	AAR=0	AAR=1
Warning	ON	OFF	2" ON / 1" OFF	OFF	OFF	OFF	0.5" ON / 3" OFF
Alarm	ON	OFF	2" ON / 1" OFF	OFF	2" ON / 1" OFF	OFF	0.5" ON / 0.5" OFF / 0.5" ON / 3" OFF

**NOTE:** When setting this function, be careful and double-check when setting the 'relay as a buzzer.' Help ensure that you carefully inspect what is connected to that relay to avoid undesired behavior. For instance, if a system or a device is connected to a relay set as a buzzer, it could be deactivated by pressing the Mute button.

## Conditions when manual reset option is chosen for Warning and Alarm

The relays and buzzer are triggered when the gas concentration level exceeds the warning/alarm thresholds. The buzzer is muted for a pre-defined period of time (parameter BMD), when MUTE button is pressed during 2 seconds. The relays and buzzer are reset, when the MUTE button is pressed and the gas concentration level is below the warning/alarm thresholds.

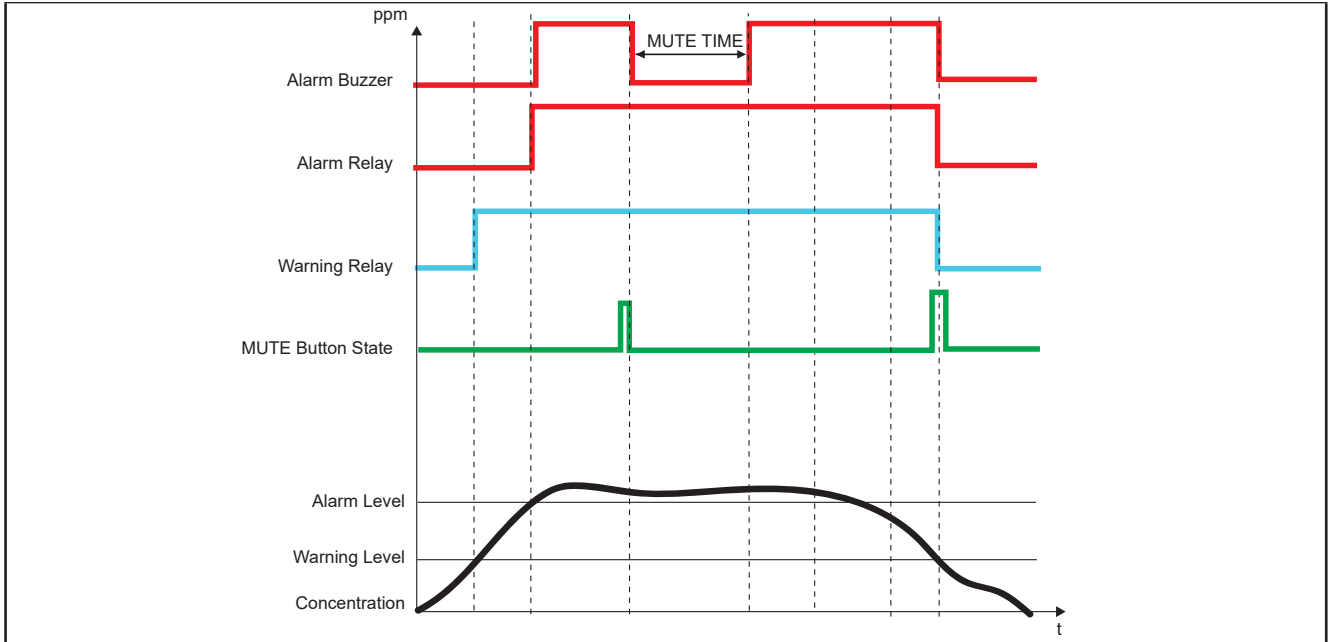

**Fig. 24.** Alarm/Warning sequences

If a warning or alarm is active, after 1 second of exposure, the alarm will be acknowledged and deactivated. If gas is still present, the detector will enter alarm or warning mode as usual, after a buzzer muting parameter duration. Acknowledge is only possible in latched alarm mode, else mute is the only reaction.

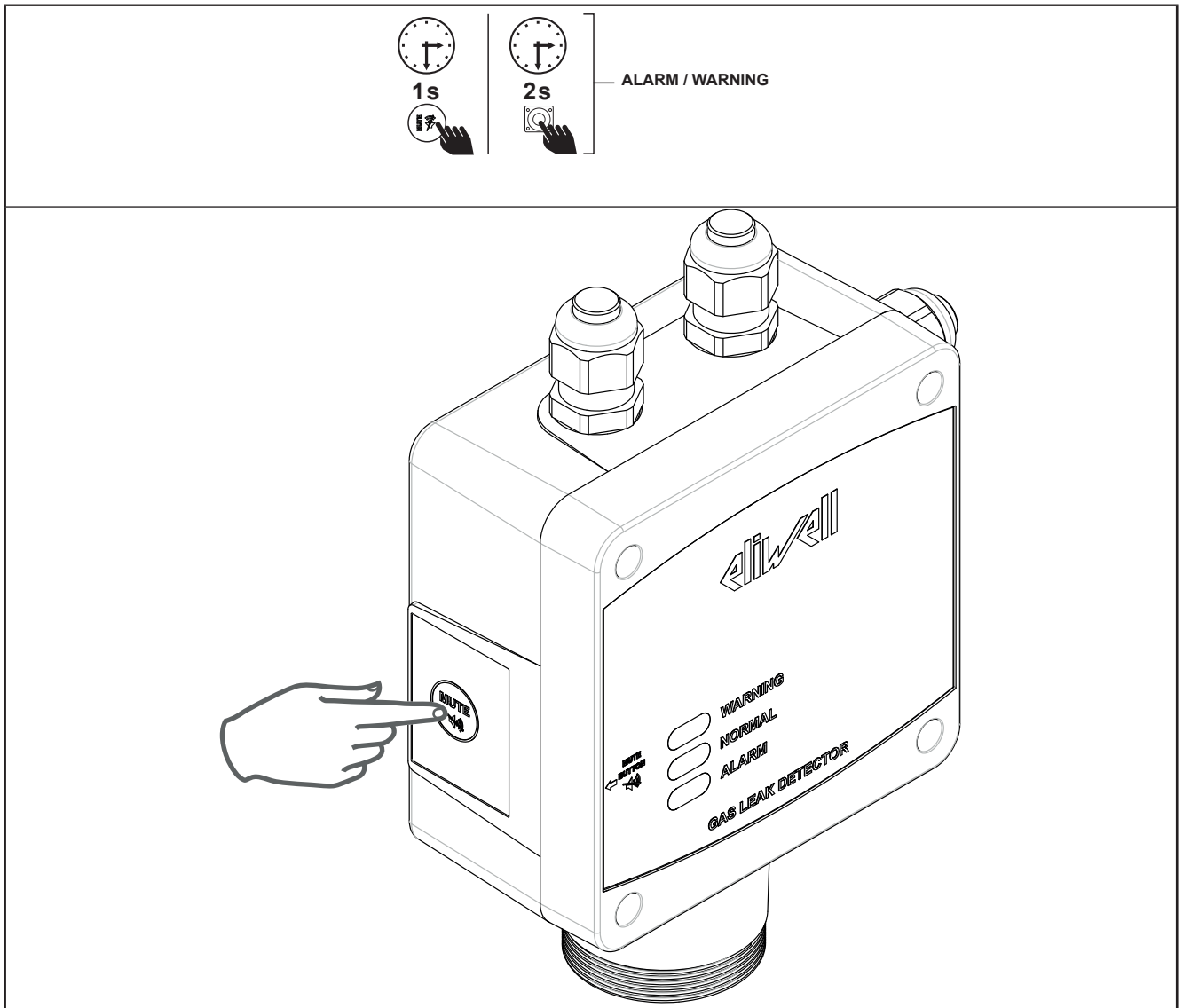

**Fig. 25.** Alarm / Acknowledge

---

## CHAPTER 6

### Appendix

---

#### 6.1. Sensor operating principle

##### 6.1.1. Semiconductor sensors

Semiconductor or metal-oxide-semiconductor (MOS) sensors are very versatile and can be used in a wide range of applications: they can measure both gases and vapours at low ppm and combustible gases at higher concentrations. The sensor is made from a blend of metal oxides. These are heated to a temperature between 150 °C (302 °F) and 300 °C (572 °F), depending on the gas to be detected. The operating temperature and composition of oxides determines the selectivity of the sensor with respect to different gases, vapours and refrigerants. Electrical conductivity increases significantly as soon as gas or vapour molecules come into contact with the sensor's surface by diffusion.

When the molecules of the selected gas come into contact with the sensor's surface, the conductivity of the semiconductor material increases significantly in proportion to the concentration of gas. Consequently, the current running through the sensor also varies. Water vapour, high ambient humidity, temperature fluctuations and low oxygen levels can alter the readings, giving a higher concentration than the actual level.

By using this technology, LKDNNext allows the gas detected to be selected based on its category. Gases are divided into three categories or groups. Group 1 includes R32 gases, group 2 those HFCs/HFOs and group 3 HCs.

Depending on the gas to be detected, the specific device that detects that category of gas needs to be purchased, and then the specific gas selected via app or Modbus.

The table in the next chapter shows the list of gases detected and the corresponding group.

For example, if needing to detect R-410A, the required device needs to be purchased, described as "Group 1". At the time of installation, then, select R-410A via app or by setting the corresponding Modbus register.

##### 6.1.2. Electrochemical sensors

Electrochemical sensors measure the partial pressure of gases in atmospheric conditions. The monitored ambient air diffuses through a membrane into a liquid electrolyte inside the sensor. Immersed in the electrolyte are a measuring electrode, a counter electrode and a reference electrode. An electronic circuit with a potentiometer supplies a constant voltage between the measuring electrode and the reference electrode. The voltage, the electrolyte and the material used to make the electrodes are selected according to the gas being measured, so that this is correctly transformed electrochemically on the electrode for measurement and thus a current is generated that flows through the sensor. The current value is proportional to the concentration of gas. At the same time, oxygen from the ambient air reacts with the counter electrode. At an electronics level, the current signal is amplified, digitised and corrected based on other control parameters (e.g. ambient temperature).

##### 6.1.3. Pre-calibrated sensors and devices

Pre-calibrated sensors and devices are supplied with the calibration certificate included in the packaging, in addition to the instruction sheet.



## 6.2. Sensor replacement procedure

- Acquire a pre-calibrated sensor module with the same part number as the one mounted on the detector.
- Disconnect power

LKDNext is provided with glands loose. IP degree depends on proper installation.

### ⚠ WARNING

#### IP DEGREE LOST

- Install and operate this equipment according to the conditions described in the Environmental and electrical characteristics.
- Verify presence and correct position of cable glands gasket and relevant caps.
- Only use screws provided with the package to close the lid.
- Tighten screws in conformance with the torque specifications.

**Failure to follow these instructions can result in death, serious injury, or equipment damage.**





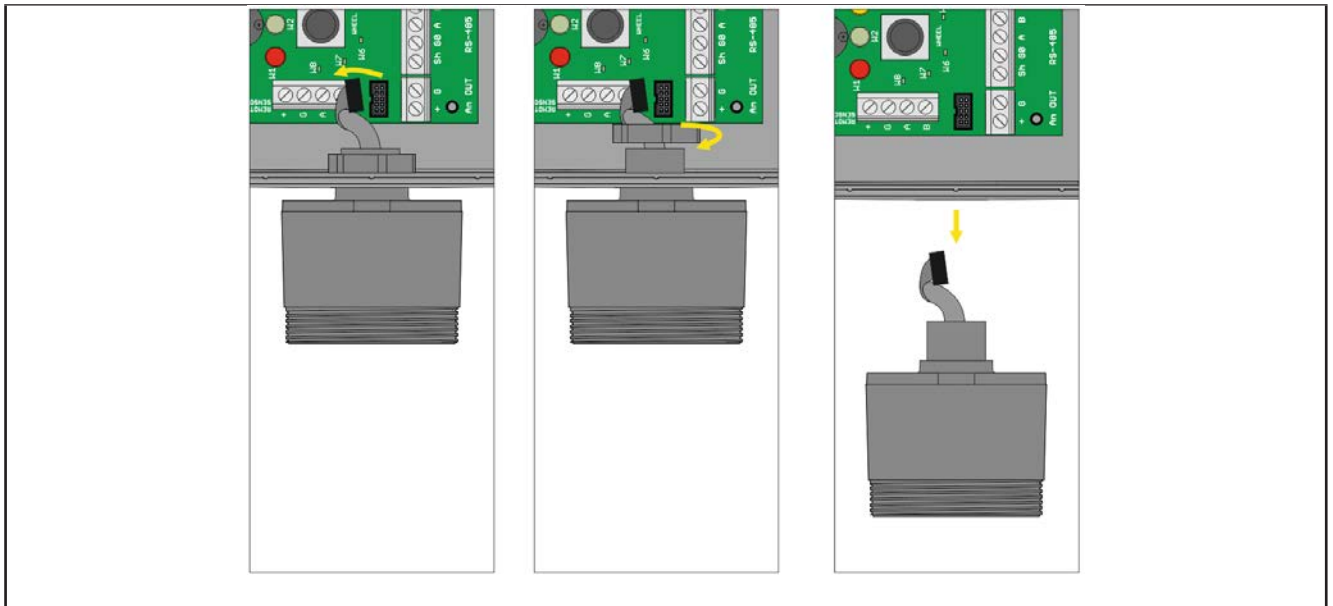

### Built-in version

- Open the cover
- Disconnect the sensor connector (E)
- Unscrew the sensor module from the case
- Screw in the new sensor module
- Plug-in the sensor connector to terminal (E)
- Close the cover

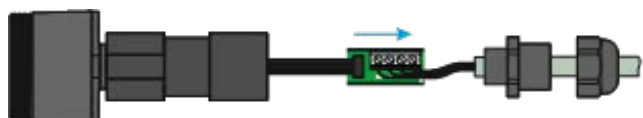

**Fig. 26.** Built-in version sensor replacement

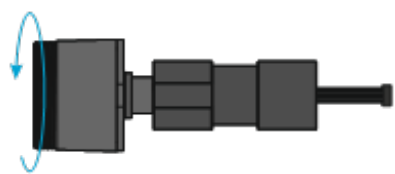
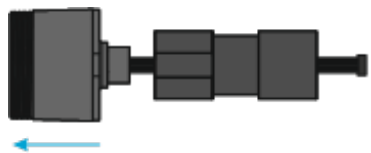
## Remote version

	<p>Loosen the cap off the cable gland so that the cable is free to move inside the cable gland.</p>
	<p>Completely unscrew the cable gland. In the event of difficulties when loosening, use pliers.</p>
	<p>Pull out the electronic board from its housing by pulling the remote sensor cable</p>
	<p>Unplug the sensor connector from the electronic board</p>
	<p>Unscrew the sensor module from the tube so as to separate it from the other parts of the device</p>
	<p>Pull out the sensor module</p>
	<p>Make sure the new sensor module has the same part number as the one just removed. Mount the sensor module in the opposite order to the above instructions for removal.</p>
<p align="center"><b>Fig. 27.</b> Remote version sensor replacement</p>	

## 6.3. Cleaning the device

Clean the detector with a soft cloth using water and a mild detergent. Rinse with water. Do not use alcohol, degreasers, sprays, polishes, detergents, etc.

## 6.4. Retro compatibility

Nr.	Feature	Functional	Old detector	New detector
1	ABZR Buzzer function	Old sensor module	No	Yes
		New sensor module	No	Yes
2	Mute button function	Old sensor module	No	Yes
		New sensor module	No	Yes
4	AAR LED function	Old sensor module	No	Yes
		New sensor module	No	Yes
5	WRB/ARB relay function	Old sensor module	No	Yes
		New sensor module	No	Yes
6	New thresholds for warning and alarm	Old sensor module	No	Limited (1)
		New sensor module	No	Yes
7	Sensitivity threshold	Old sensor module	No	No
		New sensor module	No	Yes
8	Modbus 43 update	Old sensor module	No	Yes
		New sensor module	No	Yes
9	Compressed curves	Old sensor module	No	No
		New sensor module	Yes	Yes
10	WRB/ARB relay function	Old sensor module	No	No
		New sensor module	Yes	Yes

(1) New detector and old sensor will have old max allowed limits but warning and alarm threshold updated. Not tied to version number but implementation date. New units are produced after 240422.

## **SUPPORT AND CONTACT INFORMATION**

T: +39 0437 166 0000

T: +39 0437 166 0060 (Italy)

T: +39 0437 166 0066 (other countries)

E: [saleseliwell@se.com](mailto:saleseliwell@se.com)

Technical helpline: +39 0437 166 0005

E: [techsuppeliwell@se.com](mailto:techsuppeliwell@se.com)

[www.eliwell.com](http://www.eliwell.com)

**MADE IN SWEDEN**

