



Dirt filters

→ FCY (permanent use)

■ Applications

- Permanent refrigerant filtering, regulation and expansion element protection in refrigerating and air conditioning installations.

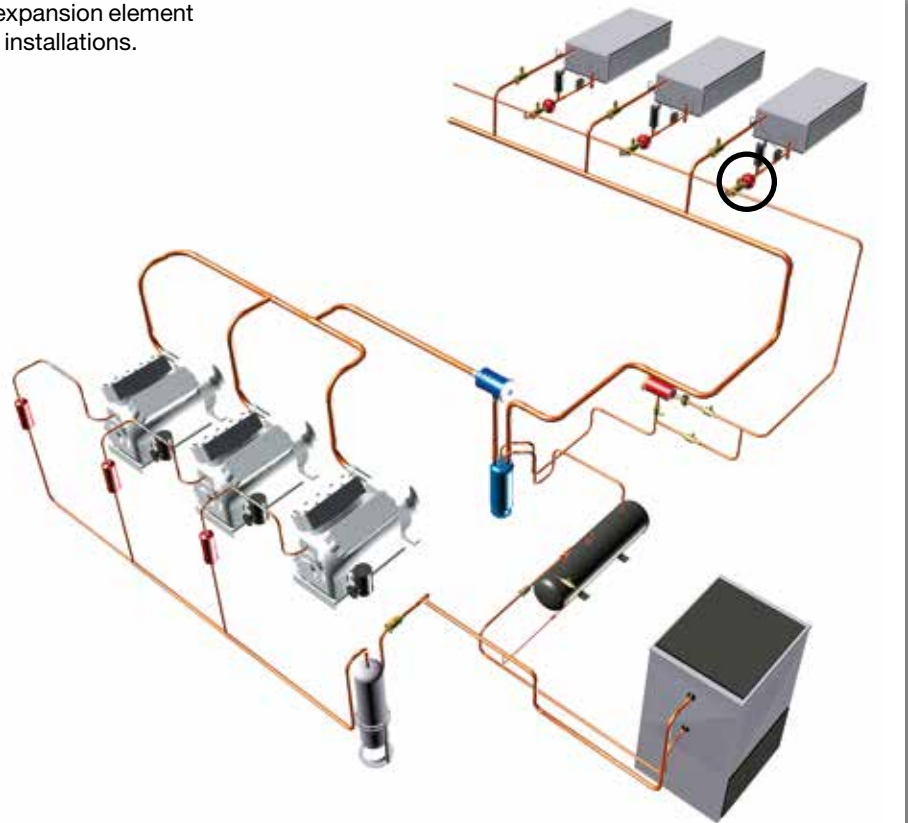

■ Functional features

- Products are compatible with CFCs, HCFCs, HFCs, CO₂, as well as with their associated oils and additives. Products are designed for use of non-hazardous refrigerants from group 2 of PED 2014/68/EU. To use CARLY components with fluids of the hydrocarbon group 1 – Propane R290, Butane R600, Isobutane R600a, Propylene R1270 – with HFOs and transcritical CO₂ and for a RANKINE organic cycle application, contact CARLY technical department.
- Product classification in CE categories is performed using the PED 2014/68/EU table, corresponding to a volume-based selection
- External steel body hermetically sealed with paint to ensure a high resistance to corrosion
- Filtering at outlet preventing propagation within the circuit of particles bigger than 25 microns, with a very low pressure drop.
- Several types of connections are possible on standard products:
 - To be screwed type SAE
 - To be brazed for tubes in inches (S)
 - To be brazed for tubes in millimeters (MMS)

■ Possible customization on demand:

- Specific connections (O-RING, ORFS, ...)

■ CARLY advantages

- Maximal working pressure: 46 bar.
- Compact products for ease of assembly in reduced footing.
- Internal retention system with minimum pressure drop, preventing the release of trapped contaminating agents.
- Very large filtering area that limits pressure drop.
- The copper-plated steel connections up to a diameter of 3/4" to be welded facilitate the brazing and allow using filler metals with a low silver percentage.



Dirt filters

→ FCY (permanent use)

■ Warning

Before selecting or installing any component, please refer to the chapter 0 - **WARNING**.

■ General assembly precautions

The installation of a component in a refrigeration system by a skilled professional, requires some precautions:

- Some are specific to each component, and in this case, they are specified in the **RECOMMENDATIONS SPECIFIC** part defined hereafter ;
- Other are general to all CARLY components, they are presented in the chapter 115 – **GENERAL ASSEMBLY PRECAUTIONS**.
- The recommendations relating to the CARLY components for the subcritical CO₂ applications are also developed in chapter 115 – **GENERAL ASSEMBLY PRECAUTIONS**.

■ Recommendations specific to the FCY dirt filters

- FCY dirt filters are to be mounted on the liquid line between the receiver and the expansion element.
- Never use these dirt filters on the oil line; in such a case, use HCYF oil filters, or HYDROIL filter driers for POE oils (refer to chapters 45 and 47).
- The refrigerant flow direction is indicated by an “IN” mark in the inlet shell of the filter drier and by an arrow on the filter tag. It must be necessarily respected.
- We recommend the vertical mounting of the dewatering filter with a top-down fluid flow direction in order to favour its filling when in operation and a rapid flow of the fluid when the installation is shut down.
- Be careful to properly select the solenoid valves located downstream of the filters; their oversizing could cause liquid hammer phenomena hindering the filters’ proper mechanical behaviour; these liquid hammer phenomena can originate from other sources, in long-piping installations; in case of doubt, it is preferable to use FILTRY dirt filters.
- Never install the filters in an area of the circuit that can be isolated.
- Never trap refrigerant in its liquid state (between a check valve and a solenoid valve, for instance).
- It is mandatory to change the dirt filters when the pressure drop measured in filter is too important. CARLY recommends this operation at least once a year as prevention.
- Make sure that the piping can support without deformation the weight of the dirt filter ; otherwise, provide for the attachment of the dirt filter with a clamp on a stable part of the installation.



Dirt filters

→ FCY (permanent use)

■ Technical features

CARLY references	Connections ⁽¹⁾		CARLY references	Connections ⁽¹⁾		Drawing Nb	Filtering surface cm ²	Dimensions mm	
	To screw SAE inch	To solder ODF inch		To solder ODF mm	Connections types ⁽¹⁾			Ø2	L
FCY 702	1/4				1	1	40	76	92
FCY 702 S		1/4	FCY 702 MMS	6	2	2	40	76	82
FCY 703	3/8				1	1	40	76	98
FCY 703 S		3/8	FCY 703 MMS	10	2	2	40	76	82
FCY 894	1/2				1	1	65	96	106
FCY 894 S		1/2	FCY 894 MMS	12	2	2	65	96	86
FCY 895	5/8				1	1	65	96	110
FCY 895 S/MMS		5/8	FCY 895 S/MMS	16	2	2	65	96	90
FCY 896 S		3/4	FCY 896 MMS	18	2	2	65	96	96
FCY 897 S/MMS		7/8	FCY 897 S/MMS	22	2	2	65	96	110
FCY 899 S		1 1/8	FCY 899 MMS	28	3	2	65	96	120
FCY 8911 S/MMS		1 3/8	FCY 8911 S/MMS	35	3	2	65	96	140

⁽¹⁾ Chapter «Connection features and drawings» (refer to chapter 114).

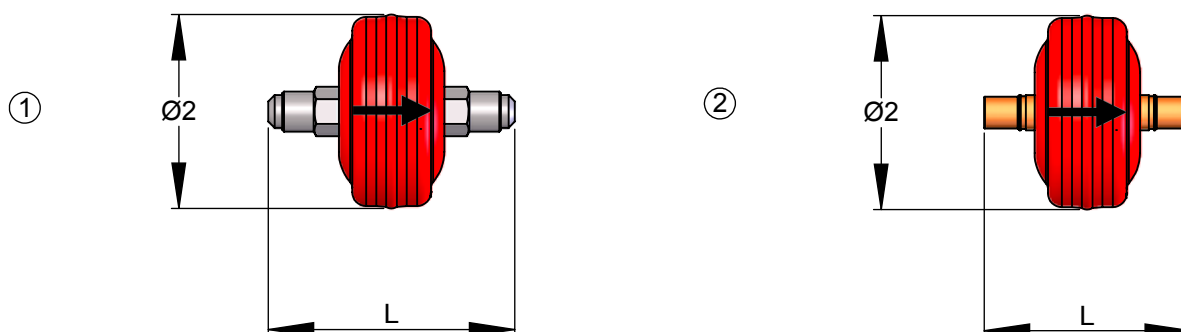

CARLY references	Volume V L	Maximal working pressure PS bar	Working pressure ⁽¹⁾ PS BT bar	Maximal working temperature TS maxi °C	Minimal working temperature TS mini °C	Working temperature ⁽¹⁾ TS BT °C	CE Category ⁽²⁾	
								FCY 702
FCY 702 S	FCY 702 MMS	0,15	46	15	100	-40	-30	Art4§3
FCY 703	0,15	46	15	100	-40	-30	Art4§3	
FCY 703 S	FCY 703 MMS	0,15	46	15	100	-40	-30	Art4§3
FCY 894	0,26	46	15	100	-40	-30	Art4§3	
FCY 894 S	FCY 894 MMS	0,26	46	15	100	-40	-30	Art4§3
FCY 895	0,26	46	15	100	-40	-30	Art4§3	
FCY 895 S/MMS	0,26	46	15	100	-40	-30	Art4§3	
FCY 896 S	FCY 896 MMS	0,26	46	15	100	-40	-30	Art4§3
FCY 897 S/MMS	0,27	46	15	100	-40	-30	Art4§3	
FCY 899 S	FCY 899 MMS	0,29	46	15	100	-40	-30	Art4§3
FCY 8911 S/MMS	0,29	46	15	100	-40	-30	Art4§3	

⁽¹⁾ The working pressure is limited to the PS BT value when working temperature is lower than or equal to TS BT value.

⁽²⁾ Classification by volume, according to PED 2014/68/EU (refer to chapter 0).



Dirt filters

→ FCY (permanent use)

■ Weights and packaging

CARLY references	Unit weight kg		Packaging number of pieces	CARLY references	Unit weight kg		Packaging number of pieces
	With packaging	Without packaging			With packaging	Without packaging	
FCY 702	0,39	0,35	16	FCY 895	0,67	0,60	1
FCY 702 S & MMS	0,39	0,35	16	FCY 895 S/MMS	0,67	0,60	1
FCY 703	0,44	0,40	16	FCY 896 S & MMS	0,67	0,60	1
FCY 703 S & MMS	0,44	0,40	16	FCY 897 S/MMS	0,72	0,65	1
FCY 894	0,57	0,50	1	FCY 899 S & MMS	0,72	0,65	1
FCY 894 S & MMS	0,57	0,50	1	FCY 8911 S/MMS	0,92	0,85	1