



Cleaning filters for suction line (temporary use, special burnout)

→ FNCY

■ Applications

- Reinforced refrigerant circuits cleaning and decontamination in refrigerating and air conditioning installations.
- Temporary use for:
 - new installations during start-up period for a very efficient protection of compressors against all types of dirt.
 - existing installations for an efficient refrigerant cleaning after compressor burnout.

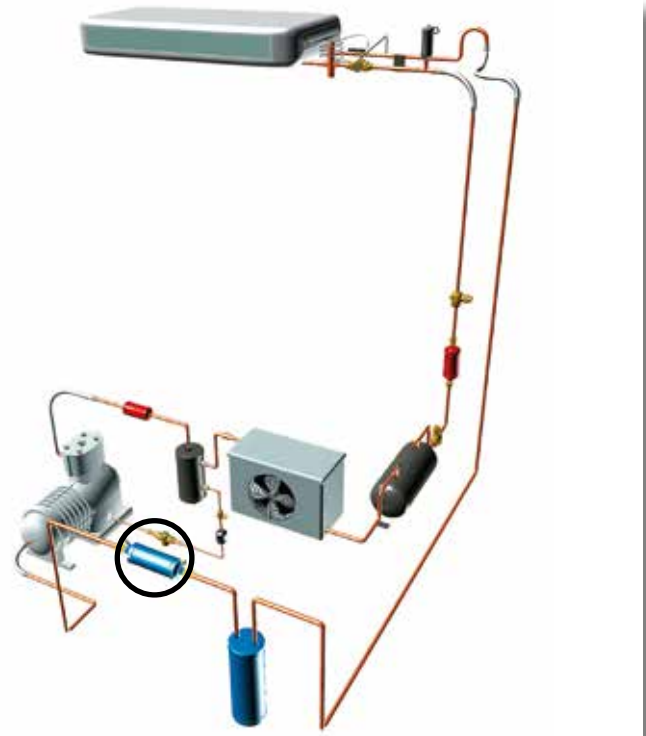

■ Functional features

- Products are compatible with CFCs, HCFCs, HFCs, CO₂, as well as with their associated oils and additives. Products are designed for use of non-hazardous refrigerants from group 2 of PED 2014/68/EU. To use CARLY components with fluids of the hydrocarbon group 1 – Propane R290, Butane R600, Isobutane R600a, Propylene R1270 – with HFOs and transcritical CO₂ and for a RANKINE organic cycle application, contact CARLY technical department.
- Product classification in CE categories is performed using the PED 2014/68/EU table, corresponding to a volume-based selection.
- Hermetically sealed outer steel enclosure with paint to ensure a high resistance to corrosion.
- Filtering at outlet preventing propagation within the circuit of particles bigger than 10 microns, with a very low pressure drop.
- No desorption, even at high temperatures.
- They integrate all the elements of the filter driers DCY, plus :
 - A permanent magnet located at the intake that traps the steel particles.
 - Active charcoal to contain the waxes, the oily sludge, etc.
 - A felt core for an optimal filtration rate (which is not present in filters NCY)
 - Two access valves for checking pressure, which facilitates the monitoring of filter blocking.
- Several types of connections are possible on standard products:
 - To be screwed type SAE
 - To be brazed for tubes in inches (S)
 - To be brazed for tubes in millimeters (MMS).



Possible customization on demand:

- Specific connections (O-RING, ORFS, ...)

■ CARLY advantages

- Maximal working pressure: 46 bar.
- Great efficiency for acid, wax binding and oily sludge neutralization at all temperatures, thanks to a fair distribution of chemical agents present in the filters: molecular sieves, activated alumina, active charcoal.
- Chemical agents in the form of free grains for increased performance and elimination of the risk of polluting the circuit with solid particles, consecutive to desiccant core break-up.
- Important retention capacity, without blocking risk and with minimum pressure drop.
- Very economical cleaning process without loss of time, because the installation is still running during the operation.
- Environmental protection and savings of refrigerant, because using these cleaning filters allows re-use of the refrigerant after pollution control.
- The copper-plated steel connections up to a diameter of 3/4" to be welded facilitate the brazing and allow using filler metals with a low silver percentage.



Cleaning filters for suction line (temporary use, special burnout)

→ FNCY

■ Warning

Before selecting or installing any component, please refer to the chapter 0 - **WARNING**.

■ General assembly precautions

The installation of a component in a refrigeration system by a skilled professional, requires some precautions:

- Some are specific to each component, and in this case, they are specified in the

RECOMMENDATIONS SPECIFIC part defined hereafter ;

- Other are general to all CARLY components, they are presented in the chapter 115 – **GENERAL ASSEMBLY PRECAUTIONS**.

- The recommendations relating to the CARLY components for the subcritical CO₂ applications are also developed in chapter 115 – **GENERAL ASSEMBLY PRECAUTIONS**.

■ Recommendations specific to the FNCY Cleaning filter driers

- The cleaning filter driers are to be mounted on the suction line between the evaporator outlet and the compressor.
- The refrigerant flow direction is indicated by an “IN” mark in the inlet shell of the filter drier and by an arrow on the filter tag. It must be necessarily respected.
- These filters are products intended for temporary use only; they should not be left permanently on the circuit.
- Closely monitor the pressure drop thanks to the two access valves, in order to

prevent shortage of the refrigerant vapour required to cool the compressor engine. The replacement of the cleaning filters is imperative when the pressure drop measured in the filter is too large.

- After compressor burnout:
 - Refer to instructions given by the manufacturer, for circuit cleaning operations and compressor replacement and apply the CARLY decontamination procedure described hereinafter.

- Visually monitor the oil condition and acidity level with TESTOIL-MAS, TESTOIL-POE and TESTOIL-3P-CO₂ acidity tests (refer to chapter 91).
- Make sure that the piping can support, without deformation, the weight of the cleaning filter; otherwise, plan the attachment of the cleaning filter with a clamp on a stable part of the installation.



Cleaning filters for suction line

(temporary use, special burnout)

→ FNCY

■ Decontamination procedure for a refrigerating circuit, after a compressor burnout, using FNCY cleaning filter driers

- 1 • Evaluate the importance of the circuit contamination. If the pollution present in the refrigerating circuit is not too high, it is economical to recover the refrigerant for re-use after treatment.
- 2 • Install replacement compressor and perform usual checks.
- 3 • Make sure that the part of the suction line immediately upstream of the compressor is clean.
- 4 • Replace all filters on the liquid line by **NCY** sealed decontamination filter of a greater capacity than that required by the new installation.
- 5 • Install special **FNCY** «burnout» filter drier, selected according to the installation capacity, on the suction line as close as possible to the compressor
- 6 • For reverse cycle systems, **FNCY** should be installed between the inversion valve and the compressor.
- 7 • Check circuit air-tightness according to the art.
- 8 • Make vacuum in the installation.
- 9 • Put circuit back under pressure.
- 10 • Power up the installation.
Monitor **FNCY** pressure drop evolution using the valves provided to that effect.
- 11 • Replace filter if pressure drop becomes too important.
The acceptable values are:
 - 0.15 bar** for a low temperature application
 - 0.25 bar** for a positive refrigeration application
 - 0.50 bar** for an air conditioning applicationIncrease of pressure drop indicates that the **FNCY** is performing its decontamination role.
- 12 • Monitor system operation during the first four hours (this monitoring must be increased when the compressor is hermetic or hermetic accessible). Replace **FNCY** as often as necessary until pressure drop in **FNCY** remains acceptable.
- 13 • After 48 hours of operation in decontamination phase, proceed to an oil sampling; visually inspect the sampling's condition and check the oil acidity level using **TESTOIL** oil acidity tests: **TESTOIL-POE** for polyol-ester oils or **TESTOIL-MAS** for synthetic alkylbenzene mineral oils or **TESTOIL-3P-CO₂** in case of an installation running with CO₂ (refer to chapter 91). If this sampling shows a non-satisfactory quality, drain oil, replace oil filter **HCFY** or **HYDROIL** and **FNCY**.

Repeat the operation starting from phase 10.
- 14 • After about 15 days, proceed to a new oil analysis by repeating phase 14 operation.
If it is satisfactory, repeat the operation starting from phase 1.
- 15 • When the procedure is finished, replace the cleaning filter **FNCY** by an equivalent filter **FACY** and the cleaning filter **NCY** by an equivalent filter drier **DCY**.

▲ This process ensures complete circuit decontamination and pollution control, thus protecting the new compressor and all the other components of a refrigerating circuit after compressor burnout.



Cleaning filters for suction line (temporary use, special burnout)

→ FNCY

■ Selection table

CARLY references	Connections		CARLY references	Connections To solder ODF mm	Refrigerating capacity kW ⁽¹⁾				Dehydratable refrigerant capacity kg of refrigerant ⁽³⁾						
	To screw SAE inch	To solder ODF inch			R134a	R404A	R22 R407C R410A R407F	R744 ⁽²⁾	R22		R134a R410A		R404A R507		R744
									R407C	R407F	24 °C	52 °C	24 °C	52 °C	
FNCY 283	3/8				1,37	0,98	1,49	1,5	38,5	32,5	40	38,5	61	34	23,4
FNCY 284	1/2				3,93	2,81	4,28	4,4	38,5	32,5	40	38,5	61	34	23,4
FNCY 285	5/8				6,59	4,70	7,17	7,4	38,5	32,5	40	38,5	61	34	23,4
FNCY 285 S/MMS		5/8	FNCY 285 S/MMS	16	6,59	4,70	7,17	7,4	38,5	32,5	40	38,5	61	34	23,4
FNCY 286 S		3/4	FNCY 286 MMS	18	11,05	7,90	12,02	12,4	38,5	32,5	40	38,5	61	34	23,4
FNCY 287 S/MMS		7/8	FNCY 287 S/MMS	22	17,02	12,16	18,52	19,1	38,5	32,5	40	38,5	61	34	23,4
FNCY 489 S		1 1/8	FNCY 489 MMS	28	21,56	15,40	23,45	24,1	68,5	57,0	71	68,5	111	61	41,6
FNCY 4811 S/MMS		1 3/8	FNCY 4811 S/MMS	35	41,91	29,94	45,60	46,9	68,5	57,0	71	68,5	111	61	41,6
FNCY 4813 S		1 5/8	FNCY 4813 MMS	42	45,85	32,75	49,88	51,4	68,5	57,0	71	68,5	111	61	41,6

⁽¹⁾ Refrigerating capacities according to Standard ARI 730-2001 for $T_o = 4.4$ °C, $T_k = 32$ °C.
If different conditions, refer to correction factors in chapter 112.

⁽²⁾ Refrigerating capacities Q_n for $T_k = -10$ °C and $T_o = -40$ °C
If different conditions, refer to correction factors in chapter 112.

⁽³⁾ Dehydratable refrigerant capacity according to Standard ARI 710-86.

Nota: the diameter of connections must not be inferior to the diameter of the main pipe.



Cleaning filters for suction line (temporary use, special burnout)

→ FNCY

■ Technical features

CARLY references	Connection types ⁽¹⁾	Drawing Nb	Filtering surface cm ²	Volume desiccation products cm ³	Dimensions mm			
					Ø1	Ø2	L	
FNCY 283	1	1	150	290	70	76	226	
FNCY 284	1	1	150	290	70	76	230	
FNCY 285	1	1	150	290	70	76	234	
FNCY 285 S/MMS	2	2	150	290	70	76	214	
FNCY 286 S	FNCY 286 MMS	2	2	150	290	70	76	220
FNCY 287 S/MMS		2	2	150	290	70	76	234
FNCY 489 S	FNCY 489 MMS	3	2	356	550	89	96	317
FNCY 4811 S/MMS		3	2	356	550	89	96	337
FNCY 4813 S	FNCY 4813 MMS	3	2	356	550	89	96	337

⁽¹⁾ Chapter «Connection features and drawings» (refer to chapter 114).

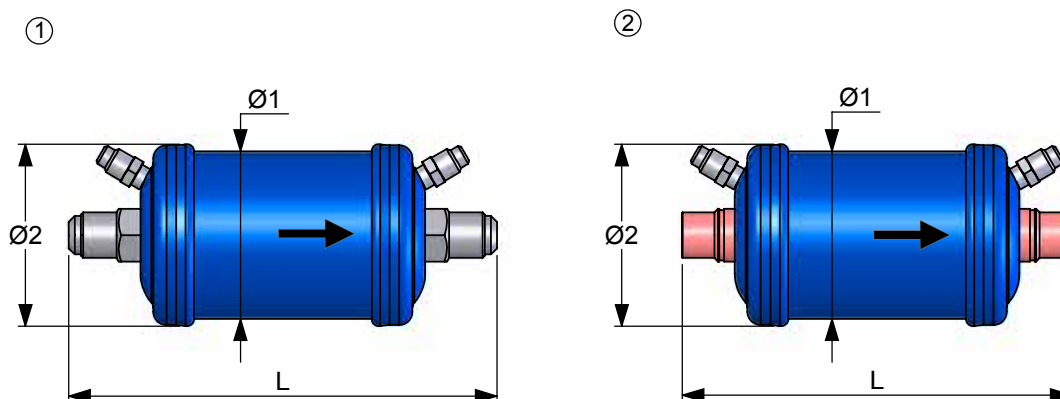

CARLY references	Volume V L	Maximal working pressure PS bar	Working pressure ⁽¹⁾ PS BT bar	Maximal working temperature TS maxi °C	Minimal working temperature TS mini °C	Working temperature ⁽¹⁾ TS BT °C	CE Category ⁽²⁾	
								FNCY 283
FNCY 284	0,58	46	15	80	-40	-30	Art4§3	
FNCY 285	0,58	46	15	80	-40	-30	Art4§3	
FNCY 285 S/MMS	0,58	46	15	80	-40	-30	Art4§3	
FNCY 286 S	FNCY 286 MMS	0,59	46	15	80	-40	-30	Art4§3
FNCY 287 S/MMS		0,59	46	15	80	-40	-30	Art4§3
FNCY 489 S	FNCY 489 MMS	1,39	46	15	80	-40	-30	I
FNCY 4811 S/MMS		1,40	46	15	80	-40	-30	I
FNCY 4813 S	FNCY 4813 MMS	1,42	46	15	80	-40	-30	I

⁽¹⁾ The working pressure is limited to the PS BT value when working temperature is lower than or equal to TS BT value.

⁽²⁾ Classification by volume, according to PED 2014/68/EU (refer to chapter 0).



Cleaning filters for suction line (temporary use, special burnout)

→ FNCY

■ Weights and packaging

CARLY references	Unit weight kg		Packaging number of pieces
	With packaging	Without packaging	
FNCY 283	1,09	1,05	1
FNCY 284	1,14	1,10	1
FNCY 285	1,19	1,15	1
FNCY 285 S/MMS	1,19	1,15	1
FNCY 286 S & MMS	1,22	1,17	1
FNCY 287 S/MMS	1,24	1,20	1
FNCY 489 S & MMS	2,22	2,15	1
FNCY 4811 S/MMS	2,42	2,35	1
FNCY 4813 S & MMS	2,47	2,40	1