

AC axial fan

sickled blades (S series)
with guard grille for short nozzle

**ebm-papst Mulfingen GmbH & Co. KG**

Bachmühle 2 · D-74673 Mulfingen

Phone +49 7938 81-0

Fax +49 7938 81-110

info1@de.ebmpapst.com

www.ebmpapst.com

Limited partnership · Headquarters Mulfingen
County court Stuttgart · HRA 590344

General partner Elektrobau Mulfingen GmbH · Headquarters Mulfingen
County court Stuttgart · HRB 590142



Nominal data

| | | | |
|-------------------------------|-------------------|------|------|
| Type | S4E400-AP02-44 | | |
| Motor | M4E074-EI | | |
| Phase | | 1~ | 1~ |
| Nominal voltage | VAC | 230 | 230 |
| Frequency | Hz | 50 | 60 |
| Type of data definition | | fa | fa |
| Valid for approval / standard | | CE | CE |
| Speed | min ⁻¹ | 1430 | 1700 |
| Power input | W | 160 | 240 |
| Current draw | A | 0.73 | 1.06 |
| Motor capacitor | µF | 6 | 6 |
| Capacitor voltage | VDB | 400 | 400 |
| Max. back pressure | Pa | 150 | 75 |
| Max. ambient temperature | °C | 60 | 60 |
| Starting current | A | 2.0 | 1.9 |

ml = max. load · me = max. efficiency · fa = running at free air · cs = customer specs · cu = customer unit
Subject to alterations

Data according to ErP directive

| | |
|-----------------------|--------|
| Installation category | A |
| Efficiency category | Static |
| Variable speed drive | No |
| Specific ratio* | 1.00 |

* Specific ratio = $1 + p_{fs} / 100\,000\text{ Pa}$

| | Actual | Request 2013 | Request 2015 |
|--------------------------------|-------------------|--------------|--------------|
| Overall efficiency η_{es} | 31.9 | 25.3 | 29.3 |
| Efficiency grade N | 42.6 | 36 | 40 |
| Power input P_e | kW | 0.2 | |
| Air flow q_v | m ³ /h | 2675 | |
| Pressure increase p_{fs} | Pa | 90 | |
| Speed n | min ⁻¹ | 1390 | |

Data established at point of optimum efficiency



AC axial fan

sickled blades (S series)
with guard grille for short nozzle

Technical features

| | |
|---|---|
| Mass | 6.1 kg |
| Size | 400 mm |
| Surface of rotor | Coated in black |
| Material of blades | Sheet steel, coated in black |
| Material of guard grille | Steel, phosphated and coated in black plastic |
| Number of blades | 5 |
| Direction of air flow | "V" |
| Direction of rotation | Counter-clockwise, seen on rotor |
| Type of protection | IP 44; Depending on installation and position as per EN 60034-5 |
| Insulation class | "F" |
| Humidity class | F1-2 |
| Max. permissible ambient motor temp. (transp./ storage) | + 80 °C |
| Min. permissible ambient motor temp. (transp./storage) | - 40 °C |
| Mounting position | Shaft horizontal or rotor on bottom; rotor on top on request |
| Condensate discharge holes | Rotor-side |
| Operation mode | S1 |
| Motor bearing | Ball bearing |
| Touch current acc. IEC 60990 (measuring network Fig. 4, TN system) | < 0.75 mA |
| Electrical leads | Via terminal box, integrated capacitor connected via terminal box |
| Motor protection | Thermal overload protector (TOP) wired internally |
| Cable exit | Variable |
| Protection class | I (if protective earth is connected by customer) |
| Product conforming to standard | EN 60335-1; CE |



AC axial fan

sickled blades (S series)
with guard grille for short nozzle

Product drawing

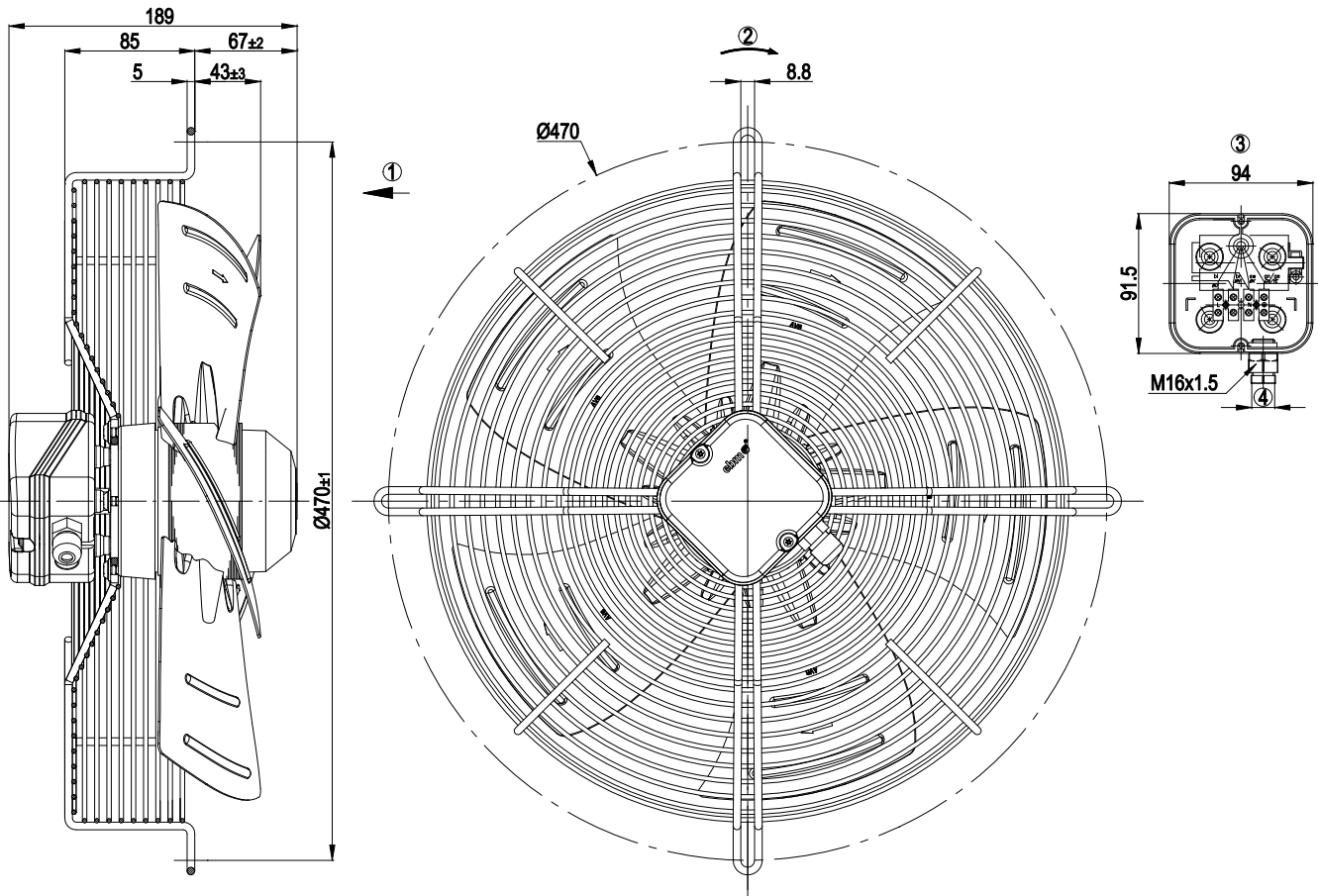

| | |
|---|--|
| 1 | Direction of air flow "V" |
| 2 | Direction of rotation counter-clockwise, seen on rotor |
| 3 | Illustration without terminal box cover |
| 4 | Kabeldurchmesser: max. 7.5 mm |

Connection screen

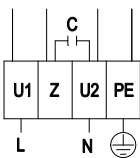

| | | | | | |
|----|--------------|---|-------|---|--------------|
| L | = U1 = blue | Z | brown | N | = U2 = black |
| PE | green/yellow | | | | |



AC axial fan

sickled blades (S series)
with guard grille for short nozzle

Charts: Air flow 50 Hz

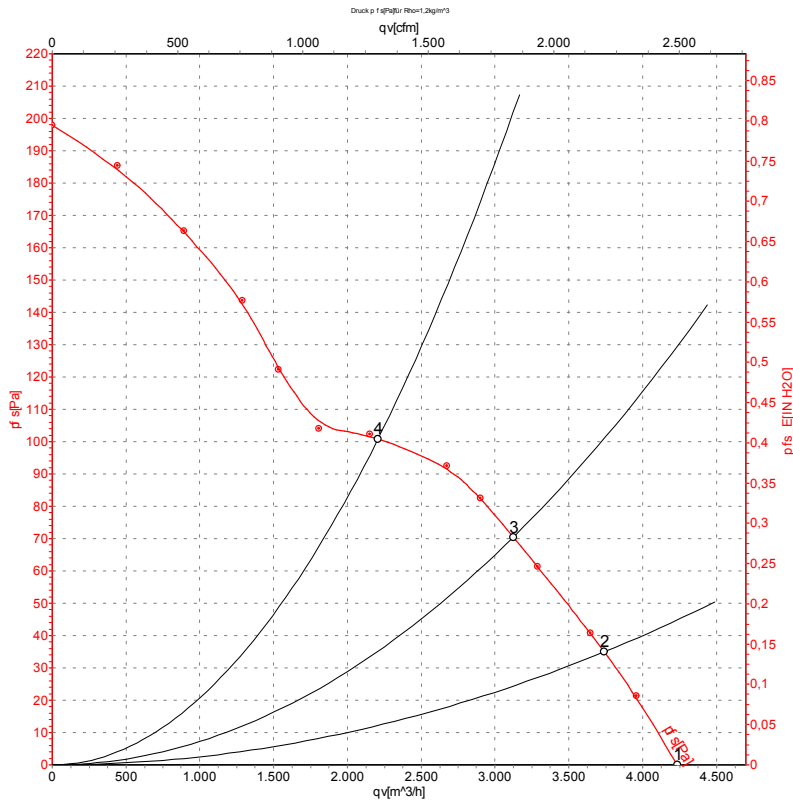

Measurement: LU-30924

Air performance measured as per ISO 5801 Installation category A. For detailed information on the measuring set-up, please contact ebm-papst. Suction-side noise levels: LwA measured as per ISO 13347 / LpA measured with 1m distance to fan axis. The values given are valid under the measuring conditions mentioned above and may vary according to the actual installation situation. With any deviation from the standard set-up, the specific values have to be checked and reviewed with the unit installed.

Measured values

| | U | f | n | P _e | I | LpA _{in} | LwA _{in} | qv | p _{fs} |
|---|-----|----|-------------------|----------------|------|-------------------|-------------------|-------------------|-----------------|
| | V | Hz | min ⁻¹ | W | A | dB(A) | dB(A) | m ³ /h | Pa |
| 1 | 230 | 50 | 1430 | 160 | 0.73 | 67 | 74 | 4235 | 0 |
| 2 | 230 | 50 | 1425 | 180 | 0.81 | 67 | 74 | 3740 | 35 |
| 3 | 230 | 50 | 1405 | 198 | 0.88 | 65 | 73 | 3125 | 70 |
| 4 | 230 | 50 | 1380 | 219 | 0.97 | 67 | 74 | 2205 | 100 |

U = Supply voltage · f = Frequency · n = Speed · P_e = Power input · I = Current draw · LpA_{in} = Sound pressure level inlet side · LwA_{in} = Sound power level inlet side · qv = Air flow
p_{fs} = Pressure increase



AC axial fan

sickled blades (S series)
with guard grille for short nozzle

Charts: Air flow 60 Hz

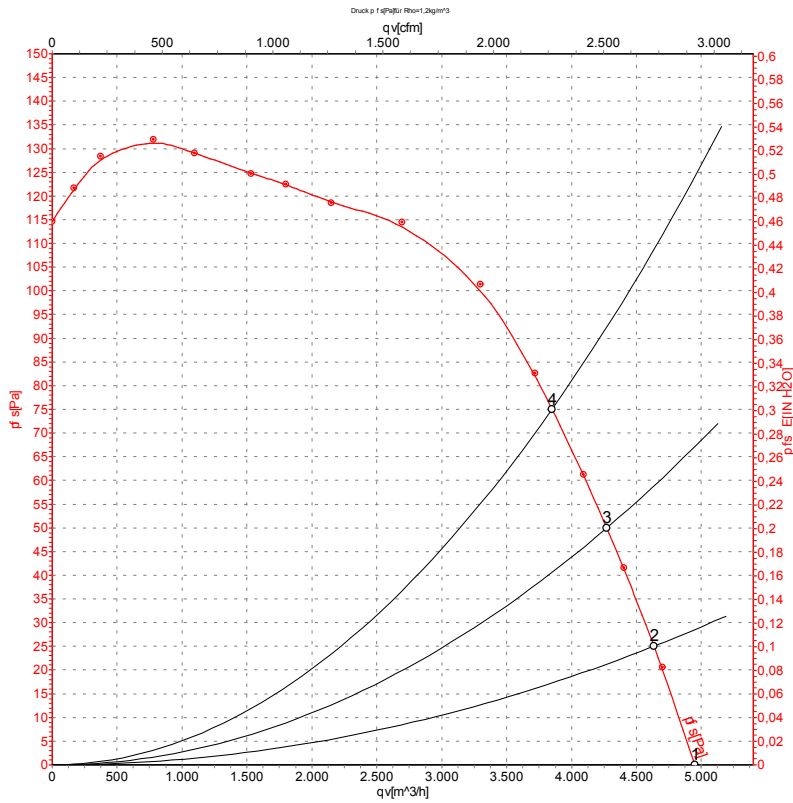

Measurement: LU-30925

Air performance measured as per ISO 5801 Installation category A. For detailed information on the measuring set-up, please contact ebm-papst. Suction-side noise levels: L_{wA} measured as per ISO 13347 / L_{pA} measured with 1m distance to fan axis. The values given are valid under the measuring conditions mentioned above and may vary according to the actual installation situation. With any deviation from the standard set-up, the specific values have to be checked and reviewed with the unit installed.

Measured values

| | U | f | n | P _e | I | L _{pA_{in}} | L _{wA_{in}} | qv | p _{fs} |
|---|-----|----|-------------------|----------------|------|------------------------------|------------------------------|-------------------|-----------------|
| | V | Hz | min ⁻¹ | W | A | dB(A) | dB(A) | m ³ /h | Pa |
| 1 | 230 | 60 | 1700 | 240 | 1.06 | 71 | 78 | 4950 | 0 |
| 2 | 230 | 60 | 1675 | 255 | 1.13 | 71 | 77 | 4635 | 25 |
| 3 | 230 | 60 | 1645 | 271 | 1.19 | 70 | 77 | 4270 | 50 |
| 4 | 230 | 60 | 1620 | 286 | 1.25 | 70 | 76 | 3850 | 75 |

U = Supply voltage · f = Frequency · n = Speed · P_e = Power input · I = Current draw · L_{pA_{in}} = Sound pressure level inlet side · L_{wA_{in}} = Sound power level inlet side · qv = Air flow
p_{fs} = Pressure increase

