

Condensing unit
Voltage Code : TZ

TAJN2446ZBR-TZ

Low Temp. Commercial (BP)

400V 3~ 50Hz / 440V 3~ 60 Hz

R452A / R404A / R448A / R449A

TAJN2446ZBR-TZ

Conditions	Frequency	Nominal Cooling Capacity		Sound Power ISO3745 / ISO 3743-1
		Watts	BTU/h	
EN13215 / R452A	50 Hz / 60 Hz	572 / 665	1950 / 2269	64 dBA
EN13215 / R404A	50 Hz / 60 Hz	635 / 738	2164 / 2517	64 dBA
EN13215 / R448A	50 Hz / 60 Hz	463 / 540	1578 / 1840	64 dBA
EN13215 / R449A	50 Hz / 60 Hz	463 / 540	1579 / 1841	64 dBA

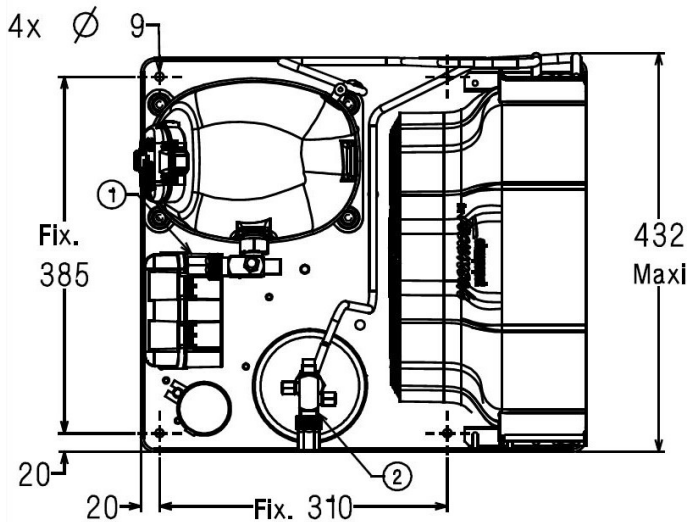
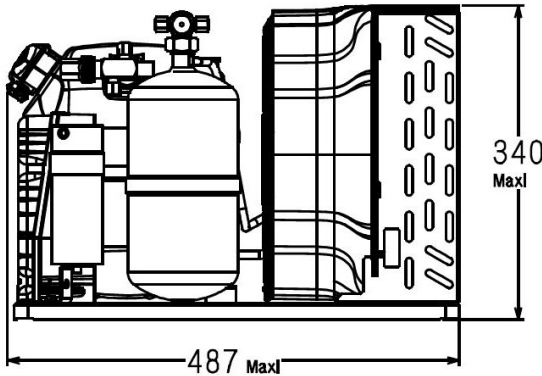

* EN13215 : T°Ambient 32.0°C / T°Evap. -35.0°C / T°Return gas temp.. 20.0°C
T°Subcooling. 3.0K

Net Weight (Kg)	33.0
Expansion device	Expansion_Valve
Air Flow (m³/h)	900 / 900
Compo Data Sheet	124NU-TZ
Elec Comp Type	TRI
Current (Amp)	
Load Rated Amp	1.7 1.8
Max Cont Current	3.3 3.6
Lock Rotor Amp	13.6 13.4
Fan	
Speed (rpm)	1200 / 1200
Power (W)	30.0
Diameter (mm)	300
Protection	Overload
IP Level	IP54
Condenser	300/3900
Liquid Receiver	
Capacity (L)	2.35
Maximum Pressure (Bars)	32.0
Suction Line	
Suction Type	Vanne Orientable
For Tubing Out Diam	12.7 (1/2")
Suction Connection Type	Brased
Liquid Line	
Liquid Line Type	Vanne Orientable
For Tubing Out Diam	9.5 (3/8")
Liquid Connecton Type	Brased
Connection Type	VR
Fan Guard	maille < à 8mm

Note : Tecumseh reserves the right to change information contained in this document without notification.



Tecumseh

TAJN2446ZBR-TZ	Tension TZ : 400V 3~ 50Hz / 440V 3~ 60 Hz
-----------------------	--

Les performances sont données dans les conditions EN13215 :	Gaz aspirés :	20.0 °C
Condition Dew	Sous refroidissement :	3.0 K
The performance data are in EN13215 conditions :	Return gas :	20.0 °C
Dew Condition	Subcooling :	3.0 K

© 2019 Tecumseh Products Company
All rights reserved

50 Hz R452A

N°6022

5 T ambience	6 T évaporation	(°C)	-40	-35	-30	-25	-20	-15	-10
25	1 P frigorifique	(Watt)	489	666	871	1103	1360	1639	1937
	2 P absorbée	(W)	486	576	674	780	895	1023	1164
	3 I absorbée	(A)	1.27	1.36	1.48	1.61	1.77	1.96	2.17
	4 Tc	(°C)	28.0	29.8	31.8	34.1	36.7	39.5	42.6
32	1 P frigorifique	(Watt)	408	572	759	970	1204	1457	1726
	2 P absorbée	(W)	473	572	679	794	918	1055	1205
	3 I absorbée	(A)	1.25	1.36	1.49	1.64	1.81	2.00	2.22
	4 Tc	(°C)	34.2	35.9	37.8	40.0	42.4	45.1	48.1
43	1 P frigorifique	(Watt)	289	430	590	768	964	1177	1404
	2 P absorbée	(W)	437	551	673	802	942	1093	1257
	3 I absorbée	(A)	1.21	1.34	1.49	1.66	1.84	2.05	2.28
	4 Tc	(°C)	44.1	45.6	47.3	49.3	51.6	54.1	56.9

60 Hz R452A

N°6022

5 T ambience	6 T évaporation	(°C)	-40	-35	-30	-25	-20	-15	-10
25	1 P frigorifique	(Watt)	577	777	1008	1267	1549	1849	2161
	2 P absorbée	(W)	568	676	795	928	1078	1248	1442
	3 I absorbée	(A)	1.26	1.37	1.51	1.68	1.88	2.10	2.36
	4 Tc	(°C)	28.3	30.5	33.0	35.8	38.9	42.2	45.9
32	1 P frigorifique	(Watt)	482	665	875	1108	1361	1630	1909
	2 P absorbée	(W)	552	670	799	941	1099	1278	1479
	3 I absorbée	(A)	1.24	1.37	1.52	1.70	1.91	2.14	2.40
	4 Tc	(°C)	35.1	37.1	39.4	42.0	44.9	48.1	51.6
43	1 P frigorifique	(Watt)	339	494	668	860	1068	1290	
	2 P absorbée	(W)	505	641	786	944	1118	1310	
	3 I absorbée	(A)	1.18	1.34	1.51	1.71	1.93	2.18	
	4 Tc	(°C)	45.8	47.6	49.6	51.9	54.6	57.5	

1 = cooling capacity 2 = power input 3 = current 4 = condensing temperature 5 = ambient temperature 6 = evaporating temperature

Nota : Tecumseh se réserve le droit de modifier les informations contenues dans ce document sans préavis.

Note : Tecumseh reserves the right to change information contained in this document without notification.



Tecumseh

TAJN2446ZBR-TZ	Tension TZ : 400V 3~ 50Hz / 440V 3~ 60 Hz
-----------------------	--

Les performances sont données dans les conditions EN13215 :	Gaz aspirés :	20.0 °C
Condition Dew	Sous refroidissement :	3.0 K
The performance data are in EN13215 conditions :	Return gas :	20.0 °C
Dew Condition	Subcooling :	3.0 K

© 2019 Tecumseh Products Company
All rights reserved

50 Hz R404A

N°5053

5 T ambience	6 T évaporation	(°C)	-40	-35	-30	-25	-20	-15	-10
25	1 P frigorifique	(Watt)	548	737	953	1193	1453	1729	2015
	2 P absorbée	(W)	520	618	721	831	949	1078	1220
	3 I absorbée	(A)	1.35	1.45	1.57	1.71	1.87	2.06	2.27
	4 Tc	(°C)	30.9	32.7	34.7	36.9	39.4	42.1	45.1
32	1 P frigorifique	(Watt)	461	635	831	1049	1284	1532	1789
	2 P absorbée	(W)	512	618	729	848	976	1115	1266
	3 I absorbée	(A)	1.34	1.45	1.58	1.74	1.91	2.11	2.33
	4 Tc	(°C)	37.0	38.6	40.5	42.6	45.0	47.6	50.4
43	1 P frigorifique	(Watt)	331	481	648	831	1028	1234	1446
	2 P absorbée	(W)	482	602	729	862	1006	1160	1328
	3 I absorbée	(A)	1.31	1.45	1.60	1.77	1.96	2.17	2.40
	4 Tc	(°C)	46.5	48.0	49.7	51.6	53.7	56.1	58.8

60 Hz R404A

N°5053

5 T ambience	6 T évaporation	(°C)	-40	-35	-30	-25	-20	-15	-10
25	1 P frigorifique	(Watt)	645	859	1102	1368	1652	1947	2243
	2 P absorbée	(W)	603	720	846	985	1139	1313	1510
	3 I absorbée	(A)	1.33	1.46	1.61	1.78	1.98	2.21	2.47
	4 Tc	(°C)	31.2	33.4	35.8	38.6	41.5	44.8	48.3
32	1 P frigorifique	(Watt)	543	738	957	1197	1451	1712	1974
	2 P absorbée	(W)	593	718	854	1001	1165	1347	1553
	3 I absorbée	(A)	1.32	1.46	1.62	1.81	2.02	2.26	2.52
	4 Tc	(°C)	37.8	39.8	42.1	44.6	47.4	50.4	53.7
43	1 P frigorifique	(Watt)	388	553	735	931	1138	1349	1561
	2 P absorbée	(W)	555	697	848	1011	1190	1389	1610
	3 I absorbée	(A)	1.29	1.45	1.63	1.83	2.06	2.31	2.59
	4 Tc	(°C)	48.2	49.9	51.9	54.1	56.5	59.3	62.3

1 = cooling capacity 2 = power input 3 = current 4 = condensing temperature 5 = ambient temperature 6 = evaporating temperature

Nota : Tecumseh se réserve le droit de modifier les informations contenues dans ce document sans préavis.

Note : Tecumseh reserves the right to change information contained in this document without notification.



Tecumseh

TAJN2446ZBR-TZ	Tension TZ : 400V 3~ 50Hz / 440V 3~ 60 Hz
-----------------------	--

Les performances sont données dans les **conditions EN13215** :
 Condition Dew
 The performance data are in **EN13215 conditions** :
 Dew Condition

Gaz aspirés : 20.0 °C
 Sous refroidissement : 3.0 K
 Return gas : 20.0 °C
 Subcooling : 3.0 K

© 2019 Tecumseh Products Company
All rights reserved

50 Hz R448A (*)

N°6926

5 T ambience	6 T évaporation	(°C)	-30	-25	-20	-15	-10
25	1 P frigorifique	(Watt)	740	970	1228	1515	1829
	2 P absorbée	(W)	639	744	858	981	1117
	3 I absorbée	(A)	1.41	1.55	1.70	1.88	2.09
	4 Tc	(°C)	32.2	34.5	37.1	39.9	43.0
32	1 P frigorifique	(Watt)	645	855	1094	1360	1651
	2 P absorbée	(W)	646	759	881	1014	1159
	3 I absorbée	(A)	1.42	1.57	1.74	1.93	2.14
	4 Tc	(°C)	38.2	40.4	42.9	45.6	48.6
43	1 P frigorifique	(Watt)	506	690	899	1134	1394
	2 P absorbée	(W)	642	770	907	1055	1215
	3 I absorbée	(A)	1.43	1.60	1.78	1.99	2.21
	4 Tc	(°C)	47.8	49.8	52.1	54.6	57.4

60 Hz R448A (*)

N°6926

5 T ambience	6 T évaporation	(°C)	-30	-25	-20	-15	-10
25	1 P frigorifique	(Watt)	858	1115	1403	1717	2056
	2 P absorbée	(W)	754	885	1032	1196	1383
	3 I absorbée	(A)	1.44	1.61	1.80	2.02	2.27
	4 Tc	(°C)	33.4	36.2	39.3	42.7	46.4
32	1 P frigorifique	(Watt)	744	979	1243	1534	1849
	2 P absorbée	(W)	760	900	1055	1228	1423
	3 I absorbée	(A)	1.45	1.63	1.83	2.06	2.31
	4 Tc	(°C)	39.9	42.5	45.4	48.6	52.1
43	1 P frigorifique	(Watt)		781	1010		
	2 P absorbée	(W)		907	1077		
	3 I absorbée	(A)		1.65	1.87		
	4 Tc	(°C)		52.4	55.0		

1 = cooling capacity 2 = power input 3 = current 4 = condensing temperature 5 = ambient temperature 6 = evaporating temperature

(*) Veuillez vous référer strictement aux Recommandations d'Utilisation et Bulletins Marketing Tecumseh du fait de la température de reflux élevée pour les applications LBP.
 (*) Due to very high discharge temperature especially on LBP conditions, please strictly refer to Tecumseh Guidelines & Marketing Bulletin when using this refrigerant.

Nota : Tecumseh se réserve le droit de modifier les informations contenues dans ce document sans préavis.
Note : Tecumseh reserves the right to change information contained in this document without notification.



Tecumseh

TAJN2446ZBR-TZ	Tension TZ : 400V 3~ 50Hz / 440V 3~ 60 Hz
-----------------------	--

Les performances sont données dans les conditions EN13215 :	Gaz aspirés :	20.0 °C
Condition Dew	Sous refroidissement :	3.0 K
The performance data are in EN13215 conditions :	Return gas :	20.0 °C
Dew Condition	Subcooling :	3.0 K

© 2019 Tecumseh Products Company
All rights reserved

50 Hz R449A (*)

N°5548

5 T ambience	6 T évaporation	(°C)	-30	-25	-20	-15	-10
25	1 P frigorifique	(Watt)	741	970	1229	1516	1829
	2 P absorbée	(W)	639	744	858	981	1117
	3 I absorbée	(A)	1.41	1.55	1.70	1.88	2.09
	4 Tc	(°C)	32.2	34.5	37.1	39.9	43.0
32	1 P frigorifique	(Watt)	645	855	1094	1360	1652
	2 P absorbée	(W)	646	759	881	1014	1159
	3 I absorbée	(A)	1.42	1.57	1.74	1.93	2.14
	4 Tc	(°C)	38.2	40.4	42.9	45.6	48.6
43	1 P frigorifique	(Watt)	506	690	900	1135	1395
	2 P absorbée	(W)	642	770	907	1055	1215
	3 I absorbée	(A)	1.43	1.60	1.78	1.99	2.21
	4 Tc	(°C)	47.8	49.8	52.0	54.5	57.3

60 Hz R449A (*)

N°5548

5 T ambience	6 T évaporation	(°C)	-30	-25	-20	-15	-10
25	1 P frigorifique	(Watt)	858	1116	1403	1718	2057
	2 P absorbée	(W)	754	885	1032	1196	1383
	3 I absorbée	(A)	1.44	1.61	1.80	2.02	2.27
	4 Tc	(°C)	33.4	36.2	39.3	42.7	46.3
32	1 P frigorifique	(Watt)	745	980	1244	1535	1850
	2 P absorbée	(W)	760	900	1055	1228	1423
	3 I absorbée	(A)	1.45	1.63	1.83	2.06	2.31
	4 Tc	(°C)	39.9	42.5	45.4	48.6	52.0
43	1 P frigorifique	(Watt)		781	1011		
	2 P absorbée	(W)		907	1077		
	3 I absorbée	(A)		1.65	1.87		
	4 Tc	(°C)		52.4	55.0		

1 = cooling capacity 2 = power input 3 = current 4 = condensing temperature 5 = ambient temperature 6 = evaporating temperature

(*) Veuillez vous référer strictement aux Recommandations d'Utilisation et Bulletins Marketing Tecumseh du fait de la température de reflux élevée pour les applications LBP.

(*) Due to very high discharge temperature especially on LBP conditions, please strictly refer to Tecumseh Guidelines & Marketing Bulletin when using this refrigerant.

Nota : Tecumseh se réserve le droit de modifier les informations contenues dans ce document sans préavis.

Note : Tecumseh reserves the right to change information contained in this document without notification.